

FOOD SHARING AMONG THE AKA HUNTER-GATHERERS IN NORTHEASTERN CONGO

Koichi KITANISHI

Faculty of Education, Yamaguchi University

ABSTRACT This paper describes and analyzes food sharing among the Aka hunter-gatherers in northeastern Congo, based on quantitative data collected during long-term field research. First, the social connotation of the "possession" of food among the Aka is analyzed. Like in other hunter-gatherer societies, Aka "possession" of food can be revealed only through the analysis of actual food sharing process. The "ownership" does not mean the exclusive right over the food, but indicates the responsibility for sharing it with others. The "owners" of food do not decide whether food is shared or not. Their concern about food sharing is only how to share it; which parts of food are given to whom. The concept of "ownership" produces the "giver" and "receiver," thus connecting food sharing with the social relationship in the Aka society. Second, informal nature of food sharing is described. The choice of receivers is not determined by the formal social relationship such as kinship, but by "face to face relationship" created in the co-residential group. This may be one of the core characteristics of food sharing in the isolated small group.

Key Words: Aka hunter-gatherers; Food sharing; Ownership; Social relationship; Camp size.

INTRODUCTION

There are several groups of hunter-gatherers in the tropical rain forest of central Africa. They utilize many kinds of forest animals and plants as materials of their tools and medicines. The most important use of forest resources for their life must be that as food. Their way of acquiring food from hunting and gathering has already been studied in detail (Tanno, 1981; Terashima et al., 1988; Thomas & Bahuchet, 1983-). Interestingly, not all of food hunted and collected is eaten at the hunting or collecting site. The majority of food is carried back to the camp and distributed among persons who are present. It has been reported that such food sharing can be observed in almost all the hunter-gatherer societies (Dowling, 1968). Leacock & Lee (1982) indicated that food sharing is one of the core features in the hunter-gatherer societies.

The Aka, whose life and society is analyzed and discussed in this paper, is one of the hunter-gatherer groups in central Africa. This paper focuses on the social aspect of food sharing, as the author (Kitanishi, 1996) has analyzed in detail the ecological aspect of food sharing among the Aka. A relationship was found between the differences in the yield of meat and honey among the Aka men and the economic and social factors in and outside the Aka society. The process of the reduction of these differences through food sharing was found to ensure all camp members of enough food.

This paper analyzes the social relationship formed and maintained by food sharing among the Aka camp members, based on the quantitative data collected in over a one-year period. The Aka moves between the forest and the village of cultivators, sometimes

splitting into small groups, then merging into a larger group after a period. Special focus is on the relationship between food sharing and the change in the camp size and composition.

Previous discussion on food sharing among the hunter-gatherers can be roughly divided into three arguments. First, food sharing is regarded as ecological adaptation. Formerly, it was thought that food sharing was indispensable for the subsistence of hunter-gatherers, because food supply of the hunter-gatherer societies dependent on wild animals and plants was poor and unreliable (Service, 1966). The concept of "original affluent society" helped alter such view (Sahlins, 1972). Wiessner (1982), who studied the Bushmen (San), analyzed the ecological function of food sharing more closely. She indicated that food supply uncertainty of each individual or each family in the camp was reduced by pooling; i.e., combining a sufficient number of independent units. She pointed out that food sharing was a part of the social system to reduce risk as well as a "hxaro" gift exchange network, which made it possible to pool risk beyond the camp.

Second discussion concerns the social function of food sharing. For instance, it is said that food sharing prevents conflict in the group and maintains group cohesion and cooperation (Dowling, 1968; Bahuchet, 1990). Woodburn (1982) argued that the hunter-gatherer societies with an immediate return system were "egalitarian societies," and that food sharing was a socially imposed leveling mechanism at the foundation of such societies.

Third discussion is concerned with the evolution of food distribution from the viewpoint of evolutionary ecology. Several hypotheses have been examined by the empirical data collected in the present hunter-gatherer societies (Kaplan et al., 1984; Kaplan & Hill, 1985).

In the analysis of food sharing, who gives whom which food is more important than the enumeration of the rules of food sharing. In the previous studies of food sharing in the hunter-gatherer societies focusing on the social aspect, there are several detailed descriptions of the rules of sharing, based on the role played in the hunting or kinship. In addition to the obligatory and rule-governed sharing, sharing at the owner's discretion has also been observed (Ichikawa, 1983; Bahuchet, 1990). Ingold (1986, 1988) indicated that sharing was based on the autonomy of the person rather than on the social structure such as kinship. Considering these points, I believe that the analysis of actual food sharing can reveal the social relationship in the residential groups of the hunter-gatherers.

Most of the previous studies have shown only some instances of actual food sharing. There are a few studies which have quantitatively analyzed food sharing in the whole residential groups for long duration. Kaplan & Hill (1985) quantitatively analyzed the genetic relations between food producers and consumers in Ache hunter-gatherers in Paraguay. They put forth the hypotheses of the evolution of food sharing from the viewpoint of evolutionary ecology, but did not analyze the social aspect of food sharing. Imamura (1993) described and analyzed the food sharing of the Bushmen (San) in detail. The present life of the Bushmen has changed from the former hunting and gathering life in small groups. She said that the current food sharing among the Bushmen had changed from that of the old days when Bushmen depended on wild animals and plants and associated with a small number of persons, as they now live around the well, receive rations of food and form large groups.

The concept of "possession" of food in the hunter-gatherer societies has also attracted

many scholars for a long time. Without “possession,” giving and sharing do not make sense. In “Discours sur l’Origine et les Fondements de l’Inégalité parmi les Hommes,” Rousseau said that possession came into existence when man invented agriculture (Rousseau, 1754). Such old view was the origin of the concept of “primitive communism” in early anthropology. Many anthropologists of the early part of the present century revealed that land and its resources were communally owned, whereas tools, weapon and procured food were owned individually in hunter-gatherer societies (Lee, 1988). However, it has not been made clear which kinds of rights “possession” of food in the hunter-gatherer societies are comprised of. These rights are known to vary quite substantially from one society to another. Therefore, the aim of this paper is to analyze “possession” of food among the Aka, and discuss the social relationship to which Aka food sharing gives rise.

STUDY AREA AND METHOD

The Aka, one of the groups of so-called “Pygmies,” live in the forest area of northeastern Congo, southern Central African Republic and on the eastern bank of the Oubangui River in Democratic Republic of Congo (DRC, former Zaire) (Bahuchet, 1985). Their population was estimated from 15,000 to 30,000 (Bahuchet & Thomas, 1986). They speak a Bantu language belonging to C 10 group of the classification of Guthrie (1967) (Cloarec-Heiss & Thomas, 1978).

Field research was conducted from October 1991 to November 1992 and from August 1995 to November in the vicinity of Linganga-Makaou village, the uppermost village on the Motaba River of Dongou District, Likouala Region of Congo (2° 55’ N. Lat. and 17° 10’ E. Long.). Linganga-Makaou village was founded by the Ikenga⁽¹⁾ slash-and-burn cultivators who speak a Bantu language. There are approximately 220 Ikengas in the village. Besides cultivation, they practice hunting in the forest with guns, fishing with nets, hooks, traps and fish poison in the Motaba River and its tributaries (Kitanishi, 1994, 1995). The Aka have a close relationship with these cultivators in various aspects, which will be described in another paper.

The Aka of Linganga-Makaou generally spend four to eight months a year in the forest, and stay around the village during the remaining months. Occasionally, they keep away from the village for more than one year. There were 9 camps in 1992, 12 camps in 1995 around the village, for approximately 350 Aka. Life in the forest camp is quite different from that in the village camp (Kitanishi, 1995). The Aka hunt and collect wild food in the forest, whereas in the village, they provide the cultivators with agricultural work, and mainly eat agricultural food and meat hunted with cultivators’ guns. This paper mainly analyzes food sharing in the forest camp. Although some instances of food sharing in the village camp are described, further field research is necessary for quantitative comparison of food sharing between in the forest and village camp.

Residential groups of the Aka in Linganga-Makaou consist of about 3-20 families⁽²⁾ of 15-100 persons who share kinship. The members of the residential groups almost correspond to that of the village camps. The central elder of the residential group is called *kombeti*.⁽³⁾ Occasionally, the name of *kombeti* is used to denote the residential group. The Aka themselves said that their mode of postmarital residence is uxori-

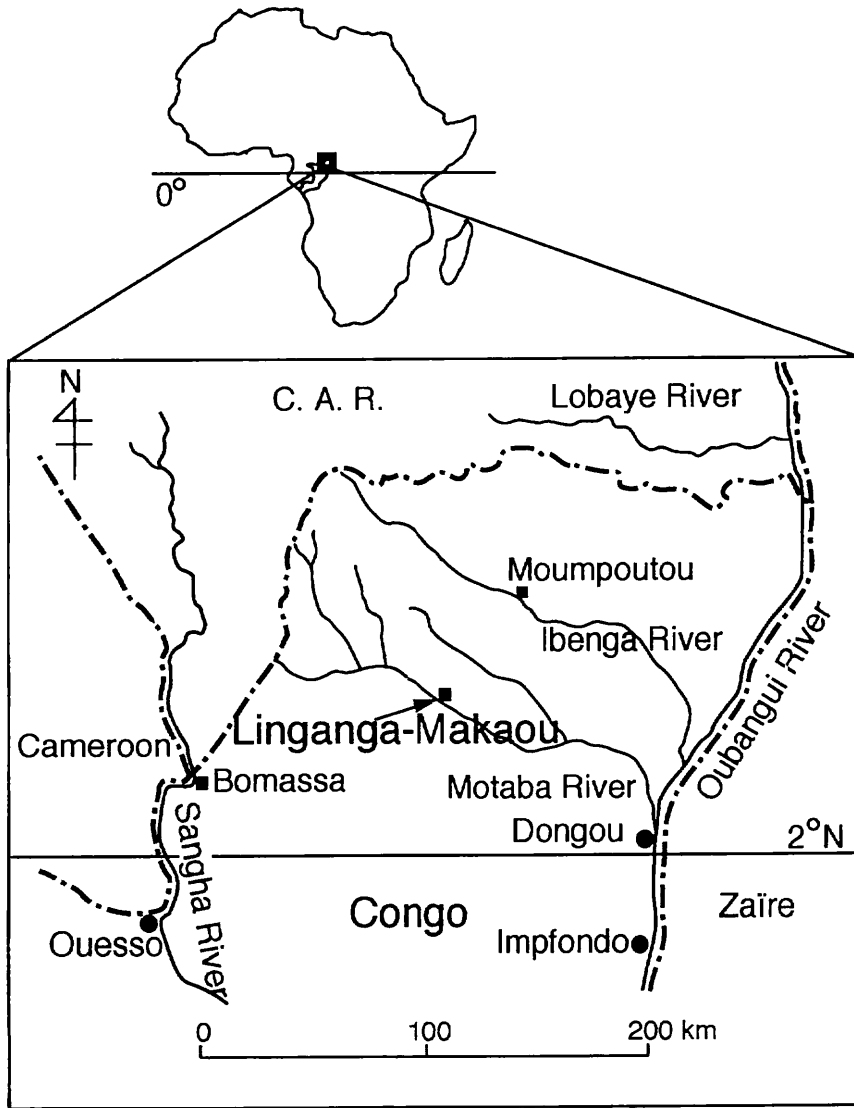

Fig. 1. The study area.

virilocal residence: i.e., virilocal residence after a certain duration of uxori-local residence and payment of bridewealth (*e.lonja*). Although a couple is certain to live in the wife's camp when they begin their marriage, they sometimes continue to stay there for a long time. The number of couples taking up uxori-local residence is, therefore, almost same as that of virilocal residence among the Aka of Linganga-Makaou.⁶¹

Flexibility of the membership of these residential groups is quite high. In addition to the change in the composition caused by marrying in and out, families may move to another residential group because of some trouble in the camp. A large residential group sometimes splits into a few small groups and live separately. Occasionally, some residential groups camp together in the forest. The number of residential groups increased by three from 1992 to 1995: One group which had lived in another cultivator village moved into Linganga-Makaou, and two groups separated from other residential groups within Linganga-Makaou.

I conducted field research mainly among the residential group comprised of about 80 persons in 1991 and 1992, which is hereafter called M group, after the initial of the *kombeti*. In 1995, I studied a residential group consisting of 43 persons, hereafter called B group.

M group was the largest group in Linganga-Makaou in 1992. M group repeated splitting into smaller groups and merging into a larger group during the study period (in detail, Fig. 3 of Kitanishi, 1995). However, this splitting and merging were not based on some subgroups of M group that Takeuchi (1995a) reported. The membership of those who lived together frequently varied. More than one-year observation of M group revealed that semi-permanent members in the same camp beyond the family were a couple and the widowed mother of the husband.

The data for food sharing of M group were collected in six periods, for 92 days (Table 1). Because about a half of the camp members returned to the village to collect caterpillars in the middle of Period 5, the camp size and composition changed. Therefore, Period 5 was divided into Period 5a before the movement and Period 5b after the movement. Although the composition of the camp of Period 5a was almost the same as Period 6, those of other periods were quite different from each other.

The location of camp in Period 4, 5 and 6 was the same. For the camp in Period 5 and 6, huts were made in two groups. Hereafter, residents at the huts on one side are called Hut-group 1, those on the other side are Hut-group 2 (Fig. 2a, 2b). Except for M4 and F4 of Hut-group 2, close kin constructed huts close together (Fig. 3a).

The composition of B group camp seldom changed in the whole study period. Food sharing of B group was researched for 11 days (Table 1). B group members could be divided into three kinship groups, which corresponded with the clustering of their huts (Fig. 2c, 3b): i.e., close kin lived close together. Hereafter, these three groups are called Hut-group 3, 4 and 5.

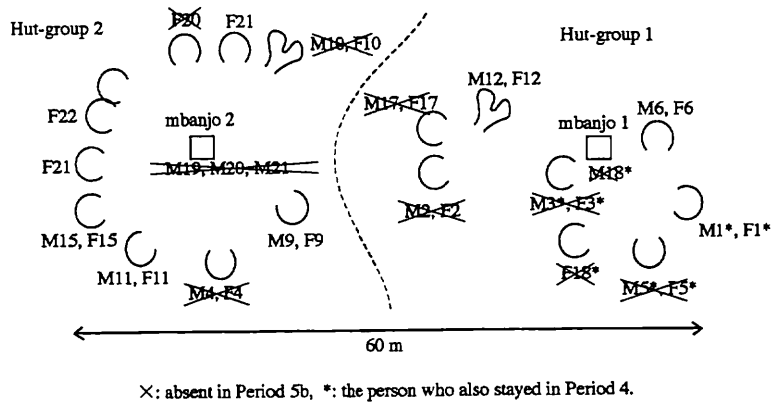

Fig. 2a. The position of huts in the camp in period 5.

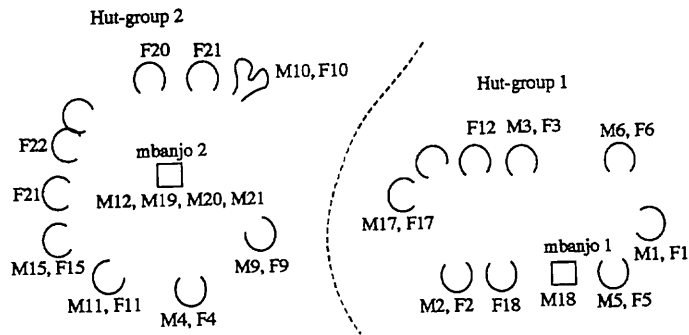

Fig. 2b. The position of huts in the camp in period 6.

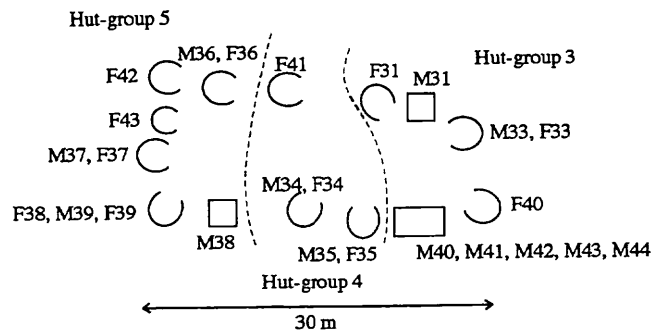

Fig. 2c. The hut position of B group.

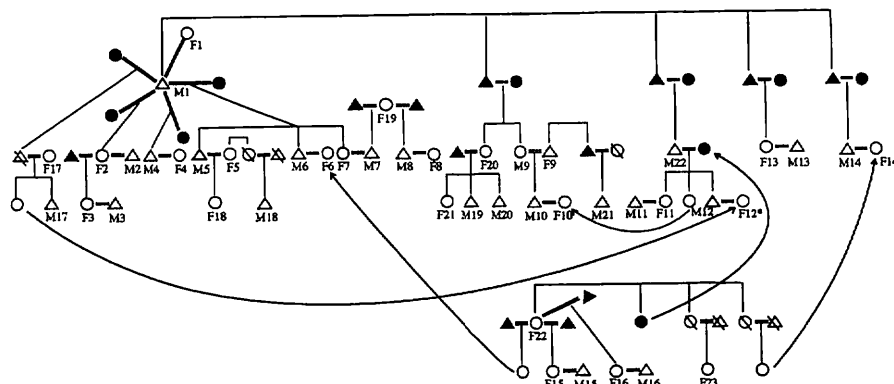

Fig. 3a. Genealogy of M group.

*: M12 and F12 married before Period 5, but divorced between Period 5 and Period 6.

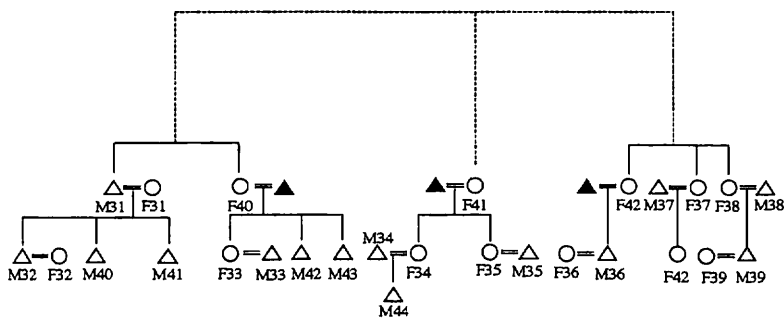

Fig. 3b. Genealogy of B group.

Table 1. Study periods and camp composition.

	M group							B group
	Period 1	Period 2	Period 3	Period 4	Period 5a	Period 5b	Period 6	
period from	11 Nov. 91	15 Dec.	10 Feb.	29 Jun.	25 Aug.	3 Sep.	10 Oct.	11 Oct. 95
to	16 Nov.	10 Jan. 92	22 Feb.	9 Jul.	2 Sep.	13 Sep.	24 Oct.	21 Oct.
days	6	27	13	11	9	11	15	11
average camp size	74.0	65.9	20.6	15.8	59.1	27.5	59.5	40.0
camp composition								
adult men*	12	7-13	4	3-6	10-12	4-6	10-12	4-9
adult women	19	8-20	6	4	13-17	9	15-17	10-12
children	43	24-45	8-12	8	30-33	13-14	31-32	22-24
Total	74	39-78	18-22	15-18	53-62	23-29	56-61	36-43

*: Married men and women are regarded as adults.

FOOD SHARING

I. Meat Sharing

(1) Hunting and three stages of meat sharing

The Aka share almost all the food in some way except for fruit eaten on the collecting site. Meat was the most frequently shared food distributed through a few stages. Meat sharing has been studied extensively within food sharing in the hunter-gatherer societies.

Because the Aka hunting method has already been described in detail by Demesse (1980), Bahuchet (1985), Takeuchi (1995b) and Kitanishi (1995), this paper will provide only the summary. The major hunting method of the Aka in Linganga-Makaou is a spring trap with steel wires (Kitanishi, 1995, 1996). About three quarters of the yield of meat was hunted with traps. The meat hunted with spears contributed to only 12.8% of the total meat yield and that with nets, 8.5%. This is different from the case in the Aka of Lobaye (southern Central African Republic) and Ibenga (northeastern Congo), where net hunting is the most important (Bahuchet, 1985; Takeuchi, 1995a).

The owner (*konja*) of the hunted animal is the owner (*konja*) of the hunting tool which immobilizes the animal. In spear hunting, the owner of the animal is the owner of the spear with which the first blow is dealt to the animal even if not fatal. The owner of the net in which an animal is caught is the owner of the animal in net hunting, and the owner of the trap (owner of the steel wire) is the owner of the trapped animal.

Sharing operates in the following three stages (Bahuchet, 1985; Kitanishi, 1996). First, some part of the butchered meat is shared among the hunters according to the roles they performed during the hunt, which I call the first distribution. This sharing is obligatory and follows strict rules. Harako (1976) and Ichikawa (1983), who studied the Mbuti in eastern DRC, called it "sharing in formal way." This first distribution is determined by the kind of the animal and the techniques used to kill it. The shared meat is called *mo.bando*. Generally, the *konja*, his wife or his children butcher the animal and distribute it.

The *konja* and those who received meat in the first distribution share the butchered meat with those present in the camp at their discretion. This second stage distribution is neither obligatory nor follows strict rules. The receivers in this distribution included temporary visitors and myself. Harako (1976) and Ichikawa (1983) called it "sharing in informal way."

The *konja*, and the men with meat from the first or second distribution give their meat to their close female relative, generally wives for married men, mothers for unmarried men. Women stew the meat along with what was given to them in the first and second distribution, in addition to several kinds of collected plant food (leaves of *Gnetum* spp., wild yam, palm oil, *Irvingia* nut oil). This stage is the only one where the centralization of food can be seen in the process of food sharing (Bahuchet, 1990): all the food acquired and received by the family concentrates in the hands of the adult woman, who cooks. Only at this stage, a family emerges as the economic unit in the Aka process of food sharing. Women share the stew with those who are present at the camp, which I call the third distribution. This is also neither obligatory nor follows strict rules. Because the third distribution is made after the addition of plant food collected by women, I will

analyze this as meal sharing in another section.

It is reported that about half of the meat hunted by the Aka in Lobaye is exchanged with the neighboring cultivators, who sell it to traders from the towns (Bahuchet, 1990). In northeastern Congo, however, almost all meat hunted by the Aka is consumed by themselves (Takeuchi, 1995b; Kitanishi, 1995).

(2) The first distribution of meat

In the first distribution of game from spear hunting and net hunting, parts of meat predetermined by rules are distributed. The major game from spear hunting is the bushpig. In the first distribution, the owner of the spear which dealt the second blow is given its dorsal midriff (*mbanja*), and the owner of the spear which dealt the third blow is given the head (*mo.soko*). If the first blow was dealt with a borrowed spear, the borrower (hunter) obtains the rump (*mbangu*). All remaining parts belong to the owner of the spear of the first blow. In net hunting, the one who actually seizes the animal is given the rib and belly (*lombo*) and intestine (*mese*). The one who sets the net is given the head.¹⁵⁾

According to the rules, about 40% of total meat of game from spear hunting (*mbanja*, *mo.soko* and *mbangu*) is given away in the first distribution. Hunters occasionally use borrow spears. Of five animals hunted with spears, only one animal was hunted with a borrowed spear. The distribution for the third blow is not always made. Only 15% of the total meat hunted with spears was actually distributed in the first distribution.

About 35% of total meat of game from net hunting (*mo.soko*, *lombo* and *mese*) is allotted to the first distribution. Usually the net owners themselves set nets. Of 24 animals hunted with nets, 17 animals were caught with nets set by the owners. Those who actually seize the netted animals are usually other persons than the net owners, or even their wives (19 animals among 24). Consequently, 20% of the total meat hunted with nets was actually distributed in the first distribution.

There is no obligation for sharing the trapped animal in the first distribution. Those who find or seize the trapped animal or help the owner carry it to the camp do not get any part of the animal as *mo.bando*. The helpers may receive some meat only in the second distribution.

The amount of meat distributed in the first distribution was quite small, 3.5% of the total meat. Major source of meat is trapping (Kitanishi, 1996), and the majority of meat directly shared in the second distribution. For this reason, it may be considered that the first distribution plays a minor role in the Aka society of Linganga-Makaou. Takeuchi (1995a) emphasized the importance of the first distribution among the Aka in Ibenga where net hunting is major hunting method. The important stage of distribution probably varies with the major hunting method of the area.

(3) The second distribution of meat

a. The second distribution

The game hunted with a spear or trap is brought to the front of the hut of the *konja* (the owner of the spear or trap), and is butchered there. Then, first and second distributions are made. The person who decides which part of the animal is given to

whom is *konja*. Occasionally, the wife of the trap owner finds and brings the game back to the camp and butchers it. In this case, if her husband is absent, she generally waits for him to return to the camp until the evening. She may share scraps of meat (*mo.soso*) before her husband returns, but waits for *konja* himself to lead the sharing. When *konja* does not return by evening, his wife directs the second distribution. In Period 5, a bushpig was caught with the trap whose owner and his wife were away at the village camp collecting caterpillars. The camp members waited for the father of *konja*'s wife to return to the camp and direct the sharing. If *konja* is absent for several days, an alternate found to determine which parts are given to whom in the sharing. This responsible person is generally a close relative of *konja*. In this case, the absent *konja* receives no meat. Because potential receivers of meat are those present at the camp (including temporary visitors), sharing is made within the camp. Meat distributed in the second distribution is sometimes cut into smaller pieces and redistributed, which I did not always follow.

In net hunting, the close female relative of *konja* (his wife in general) butchers the animal, and conducts the first and second distribution at intervals of hunting attempts in the forest.⁶⁹ When a close female relative of *konja* does not participate in the hunting, another woman who is present butchers the animal and conducts the first distribution following the rules, then returns to the camp with the remaining meat to give to *konja* or his wife. Because net owners (male) are not involved in the sharing and because receivers of meat are women, the game hunted with nets is shared only among women. Meat brought back to the camp is redistributed among the women who are present in the camp. I analyzed the second distribution of the meat hunted with nets only in the forest, because the redistribution in the camp could not be followed.

b. The proportion and number of meat parts shared in the second distribution

In the study period, 78 animals, total weight of 1405.35 kg, were hunted,⁷¹ of which 44 animals, or 860.20 kg of meat was recorded.

The species of major game vary with the hunting methods. In net hunting, blue duikers whose weight is about 5 kg are frequently caught, as well as medium-sized duikers whose weight is 15-25 kg. The major game in spear hunting is the bushpig, whose weight is more than 20 kg, and about 100 kg maximum. Although various animals were hunted with traps (e.g., small animals such as mongoose and giant forest hog weighing more than 100 kg), most of them weigh more than 20 kg. Because the size of and the way of sharing animals hunted with nets differs from those hunted with spears and traps, the proportion and number of meat shared in the second distribution in net hunting is separately analyzed.

In the second distribution of meat hunted with nets, distributors generally shared small meat, because major game of net hunting was small, and because the first distribution had already been made. All animals hunted with nets were blue duikers except for a medium-sized duiker. The weight proportion of the meat distributed in the second distribution increased with the amount of meat (Fig. 4a). At times, meat was not shared at all, and at other times the whole meat was shared. The number of receivers increased with the amount of meat, but three was the maximum (Fig. 4b).

In the second distribution of meat hunted with spears and traps, distributors shared quite larger game than those caught with nets. When the game weighed more than 20 kg,

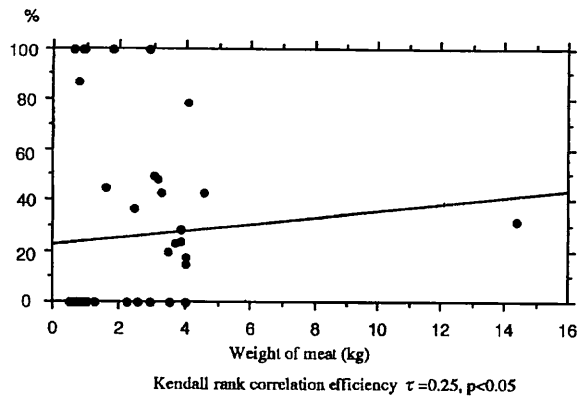

Fig. 4a. The relationship between the distributed percentage and weight of meat (net hunting).

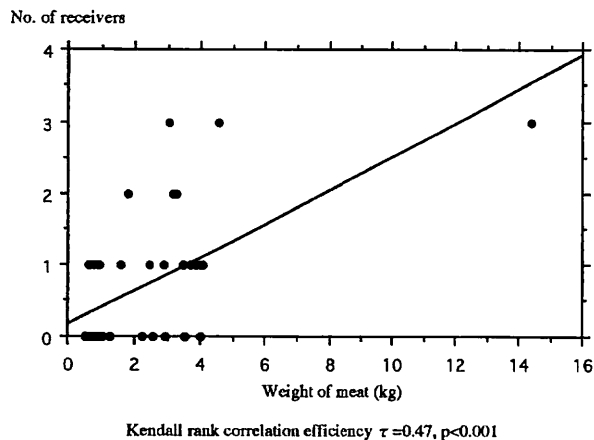

Fig. 4b. The relationship between the number of receivers and weight of meat (net hunting).

more than half was shared, but the whole meat was shared in only one case (Fig. 5a). In this case, the distributor shared one whole animal, and kept a part of the other animal that he caught the same day. When the game is weighed less than 20 kg, the cases that no meat was shared and that the whole meat was shared were observed. The number of receivers increased in proportion to the weight of the meat, with 11 at the most (Fig. 5b).

The reason why the proportion of the distributed meat and the number of receivers vary with the hunting method is that the size of animals varies with the hunting method. Hand-caught land tortoises (about 2.5 kg) are sometimes shared not at all, but sometimes shared whole, similar to sharing small game. Because small game does not interest *konja* or others, how much of it will be shared is up to the *konja*. In sharing large game, more than half of meat is shared as a matter of course. It can be said that no one can

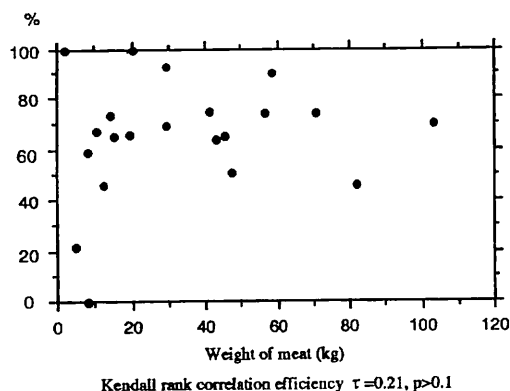

Fig. 5a. The relationship between the distributed percentage and weight of meat (except for net hunting).

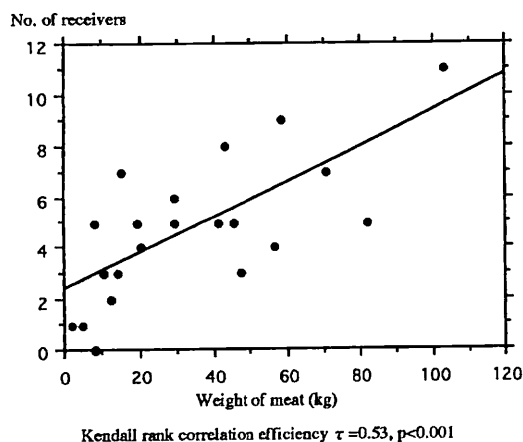

Fig. 5b. The relationship between the number of receivers and weight of meat (except for net hunting).

monopolize a large game. The number of receivers in the second distribution increases as the meat becomes larger until it reaches the number of families in the camp.

c. The relationship between the sharing, size, and composition of the camp⁽⁸⁾

While everybody at the camp has the possibility to receive some meat in the second distribution, the meat given to men and children is consequently concentrated to adult women, who cook. Therefore, in this paper, adult women will be regarded as receivers of meat.

Camp size influences the second distribution. In small camps such as in Period 3 and 4, almost all women received some meat in each sharing (detailed data in Appendix).

Table 2. The relationship between kinship and the second distribution of meat in Period 5 and 6.

	kinship index*								
	1	2	3	4	5	6	7	8	9
receiving frequency	2	3	4	8	7	2	3	0	0
weight (kg) of received meat	3.66	7.92	8.75	8.30	33.46	23.77	3.28	0	0
total No. of adult women**	8	8	21	19	25	19	8	3	2
average percentage***	22	33	16	33	27	10	30	0	0
average weight****	0.46	1.00	0.42	0.44	1.34	1.25	0.41	0	0

*: Degree of consanguinity + number of conjugal linkages (Kimura, 1992) between the giver and the receiver.

** : Total number of adult women who can receive meat (staying in the camp).

***: Receiving frequency / total No. of adult women \times 100.

****: Weight of received meat / total No. of adult women.

Table 3. The second distribution of meat within and between hut-groups.

giver	frequency receiver		weight (kg) receiver	
	Hut-group 1	Hut-group 2	Hut-group 1	Hut-group 2
	Hut-group 1	14 (13.75)	12 (12.25)	19.50 (17.25)
Hut-group 2	2 (2.25)	1 (0.75)	58.94 (78.30)	74.63 (62.61)

Note: Figures in parentheses indicate the expected weight distributed assuming that each woman received the same weight.

When the game weighed more than 20 kg, the number of receivers easily reached that of adult women in the camp. *Konja* has little choice for receivers. Presence at the camp is the only necessary and sufficient condition to receive some of meat from other members in the small camp.

In large camps such as Period 5 and 6, *konja* cannot share meat with all adult women in the camp: so the *konja* chooses the receivers. First, I analyzed the relationship between this choice and kinship between the givers and receivers (Table 2). Sharing was not much different in the frequency and amount given to close kin such as parent and children, or brothers and sisters and to others. Distant kin also received some meat. Kinship did not affect sharing by the *konja*. I then analyzed the relationship between the hut locations and *konja*'s sharing (Table 3). No difference was found between the sharing within each hut-group and between hut-groups. The second distribution in B group showed similar tendency to those in Period 5 and 6 of M group. There was also no correlation between sharing and kinship or proximity of huts.

The distributor may somewhat try so that meat is not concentrated into specific persons, families, kinship group or neighboring persons in the second distribution.

II. Sharing of Unprocessed Plant Food

The Aka woman frequently receives a small amount of plant food from other women. When she lacks plant food such as *Gnetum* leaves, *Irvingia* nuts, or palm oil to add in

her stew, other women give her a small amount. Only in the following three cases, a large amount of plant food was shared with plural persons. First was when a large amount of fruits such as *Landolphia* spp. (*mafondo*) and *Annonidium mannii* (*mobe*) was collected and brought back to the camp. Scores of fruits of *Landolphia* spp. were often collected in a collecting attempt. A fruit of *A. mannii* weighs several kilograms. These fruits are mainly distributed to children. Second case was when a large amount of wild yam (more than 5 kg) was collected. A large amount of *Dioscorea semperflorens* (*e.suma*) is frequently collected with a special digging tool called *jo*. Third case was when a large quantity of agricultural food such as cassava, leaves of cassava and palm oil fruits was brought from the village. In any case, when someone obtained a large amount of plant food, it was shared in a way similar to the second distribution of meat.

Only women were involved in plant food sharing. Although men and women together generally collect *D. semperflorens* and carry agricultural food from the village, only women lead the sharing and choose the receivers. Plant food collected and carried by men is shared by the wives. For unmarried men, their mothers or sisters. The receivers are also only women.

The sharing of *D. semperflorens* and agricultural food in Period 5 and 6 were recorded (detailed data in Appendix). The number of receivers considerably varied, from two to eight. This number may correspond to the amount of plant food as in the second distribution of meat. Because of the large camp size in Period 5 and 6, the distributors could not share the plant food with all adult women in the camp, and had to choose the receivers. I analyzed their choice as in the second distribution of meat. The distributors not always shared the plant food with a kin, and sometimes shared it with women without a close kinship. However, closer the kinship between women, the receiving rate rose, except for that between mother and daughter whose case count was small (Table 4). On the other hand, plant food was shared equally within each hut-group and between hut-groups (Table 5). In short, although plant food was shared with the whole camp as in the second distribution of meat, closeness of kinship affected the sharing somewhat.

Table 4. The relationship between kinship and unprocessed plant food sharing in Period 5 and 6.

	kinship index								
	1	2	3	4	5	6	7	8	9
receiving frequency	0	4	12	11	8	7	1	0	0
total No. of women	4	4	33	30	32	26	6	3	2
average percentage*	0.00	1.00	0.36	0.37	0.25	0.27	0.17	0.00	0.00

*: Receiving frequency / total No. of women $\times 100$.

Table 5. Frequency of plant food sharing within and between hut-groups.

giver	receiver	
	Hut-group 1	Hut-group 2
Hut-group 1	14 (12.8)	17 (18.2)
Hut-group 2	5 (5.5)	7 (6.5)

Note: Figures in parentheses indicate the expected frequency of distribution assuming that each woman received as often.

III. Meal Sharing

(1) How meal is shared

Meat hunted by men and plant food collected by women concentrate to women who stew them in front of or inside their huts. When cooking is finished, a cook puts out the pot and shares the stew in plain view of other camp members. A cook gathers plates from those whom she plans to share the stew, places them around the pot and serves. When she is short of plates, she uses pot lids or large leaves of *Marantaceae*. To share with another woman, the cook calls the children of the intended receiver and has them take the plate to their huts. The receiver shares the plate with her unmarried children. Adult men usually eat their meal together at the hut called *mbanjo*, where men generally gather in the camp. The husband or son of a cook takes the plate to *mbanjo*.⁽⁹⁾ Much stew is taking to *mbanjo*, partly because many men eat at *mbanjo*. Occasionally, men eat with his wife and children. The cook eats the remaining stew in the pot with her children. Her share is as much as or less than that given to other women. When the husband or children of the cook are absent, one or two plates are sometimes set aside for them.⁽¹⁰⁾

Both men and women can be *konja* of the stew. *Konja* of stew without meat is the woman who collected plant food and cooked it, so she leads the sharing. *Konja* of stew with meat hunted by men is explained as follows:

Occasionally, a woman is given meat by a man other than her husband to cook for him. In this case, the *konja* of stew is the man who brought the meat to the cook, even if stew contains plant food collected by the cook. This was also the case when a man offered caterpillars, larva of beetles or fish. The *konja* of stew is the person who contributed animal food, more highly appreciated than plant food by the Aka in principle. However, the person who leads the sharing is not the *konja* of meal but the cook. The *konja* receives a larger amount of stew than others in the sharing.

The *konja* of the stew cooked with the meat given by the cook's husband is the husband, based on the above principle. But I was told that the wife was also *konja* of stew, because the couple is regarded as an economic unit in the Aka society. A mother and her unmarried son is also a unit. The meat stew shared to men at *mbanjo* can be regarded as the proper portion which the man receives as *konja* of meat and stew. This is also why the men at the *mbanjo* are given much stew.

When the cook (generally *konja* of stew) is absent after cooking, other persons cannot share or eat it without *konja*'s permission. When a young girl left her stew to participate in a dance at another camp, her mother had to wait for her return. After one or two hour's wait, the mother decided that the girl did not intend to share it herself. The mother ate and shared a part of it with other women, and the remaining stew was kept for the girl.

(2) The number of distributed portions

Quantitative data of meal sharing was collected in Period 3 - 6 of M group and B group. Because women were seldom asked to cook meat by men other than their husbands or sons, the cooks were generally *konja* of stew. In this section, the cooks who lead the sharing and the receivers are analyzed. When the cook gave a plate to an adult

woman and her unmarried children, she generally told me that the receiver was the adult woman. It can be regarded that the stew was to be redistributed to her children by the mother. The children of absent mother occasionally received meals from adult women.

On the whole, the cooks give away most of the stew they cook, and mainly eat the stew cooked by other women. If it is assumed that the amount of stew remaining in the pot after sharing is same as a portion served to another woman, only 20% of stew cooked by the woman was eaten by her and her children. As much as 75% of the stew the woman ate was cooked by the other women.

The amount of stew is one of factors which determine the number of distributed portions. Small amount of stew is eaten up by the cook and her children or shared with a few women in general. When I asked the cook why, she always answered, "a small amount (*mo.soni*).” It is not possible for the cook not to share at all when a large amount of stew is cooked.

Camp size is another factor which determines the number of distributed portions. The maximum number of distributed portions depends on the camp size (Table 6).

Food restrictions also affect meal sharing. Among the Aka, some food restrictions and individual food avoidance exist (Bahuchet, 1985; Takeuchi, 1994). Because camp members know who do not eat what kind of food, cooks do not give such food to them. When an animal is hunted with a spear whose *konja* is an adolescent man (*mo.pondi*), *konja* and adult women are prohibited from eating its meat. Stew containing this meat is

Table 6. Number of distributed portions of meals in each period.

	No. of distributed portions														Total	times average
	0	1	2	3	4	5	6	7	8	9	10	11	12	14		
Period 3	1	4	1	5	1	10	5	2	0	0	0	0	0	0	29	4.1
Period 4	2	8	1	6	6	10	1	0	0	0	0	0	0	0	34	3.2
Period 5a	13	6	8	12	11	8	8	10	1	1	0	1	1	0	80	3.8
Period 5b	1	5	3	3	3	3	9	5	9	5	1	0	0	0	47	5.6
Period 6	22	19	18	15	12	12	9	8	1	1	3	1	0	1	122	3.2
B group	8	11	7	8	8	9	4	4	1	0	0	1	0	0	61	3.2
Total times	47	53	38	49	41	52	36	29	12	7	4	3	1	1	373	3.7

Table 7. The relationship between ingredients of stew and sharing.

	fish*	insect	meat	only plant	Total
frequency	4	46	216	107	373
total No. of distributed portions	12	170	925	269	1376
average No. of distributed portions**	3.0	3.7	4.3	2.5	3.7
percentage of sharing (%)***	1	87	93	76	87
percentage of sharing with males (%)****	0	65	68	33	58

*: Stew which contains fish. In general, it consists of fish and some kinds of plant food. This is same as the cases of insect and meat.

**: Total No. of distributed portions / frequency.

***: The percentage of the number of the stew the cook shared with at least one person to total number of the stew.

****: The proportion of the number of the stew the cook shared with at least one male to total number of the stew.

shared with only *mbanjo* and children.

The ingredients of the stew influence the sharing. Almost all stew containing meat was shared, whereas a quarter of stew consisting of only plant food was not (Table 7). The average number of distributed portions with meat was also quite larger than that with only plant food. This is because camp members pay more attention to the sharing of meat stew than that of plant stew, because the Aka prefer meat stew to plant stew. The average number of shared insect stew with caterpillars or larva of beetles lay between that for meat stew and that for plant stew. This corresponds with the food preference of the Aka. Meat stew was more frequently shared with men than plant stew. This is because the man offering the meat is the *konja* of stew.

(3) The relationship between camp size and meal sharing

a. Sharing among women

In this section, I will analyze how the change in camp size influences meal sharing, in particular, sharing among women and men.

In the small camps of Period 3 and 4, all women shared with and received from all other women in the camp (detailed data in Appendix). Most frequent number of distributed portions in Period 3 and 4 was six (Table 6). When a woman shared six plates, almost all the women could receive them in the small camp. Presence is the only necessary and sufficient condition to receive a portion in the small camp, similar to the second distribution of meat.

Because the cook could not share with all the women in the large camps of Period 5a and 6, she had to choose the receivers. In these periods, the stew was frequently distributed within each hut-group (Table 8): i.e., the major factor in the choice of the receivers was the location of huts in the camp. Sharing beyond hut-groups was observed when a large number of portions was shared.

Table 9 shows the relationship between kinship and meal sharing. Within each hut-group, the women with closer kinship with the cook received more frequently. However, the women without close kinship with the cook also sometimes received a meal. F4, who was no close relative of anybody in Hut-group 2, shared with and received from the Hut-group 2 more frequently than with close relatives in Hut-group 1. Exceptionally, pairs F6-F22 (daughter and mother) and F6-F15 (sisters) frequently shared meals beyond the hut-groups.

In Period 5b when half the members of Period 5a and 6 stayed at the village, all the women shared with and received from all other women except F1. Because of the reduction in the camp size, those who rarely shared stew with each other in Period 5a could share in Period 5b. Then, they seldom shared in Period 6 again. It can be said that even if a group shared meals among each other, the sharing relation is not always fixed for a long time. Women changed partners for sharing according to the circumstances such as camp size.

Although in Period 5b, the actual frequency of sharing within each hut-group was larger than that expected assuming that each woman received as often, the difference between the actual and expected frequency in Period 5b was quite smaller than that in Period 5a and 6 (Table 8). The correlation between kinship and sharing was not clear within each hut-group, because women shared with almost all women in smaller hut-

Table 8. Meal sharing within and between hut-groups in Period 5 and 6.

giver	receiver					
	Period 5a		Period 5b		Period 6	
	Hut-group 1	Hut-group 2	Hut-group 1	Hut-group 2	Hut-group 1	Hut-group 2
Hut-group 1	66.0 (30.6)	4.0 (39.4)	22.0 (15.3)	39.0 (45.8)	101.0 (52.5)	19.0 (67.5)
Hut-group 2	7.7 (72.4)	137.2 (72.4)	36.0 (57.8)	118.0 (96.3)	26.2 (83.0)	139.8 (83.0)

Note: Figures in parentheses indicate the expected frequency of distribution assuming that each adult woman received as often.

Table 9. The relationship between meal sharing and kinship in Period 5 and 6.

	kinship index									Total
	1	2	3	4	5	6	7	8	9	
Period 5a, 6										
intra-Hut-group 1	62	54	42	7	28	—	—	—	—	42
intra-Hut-group 2	64	58	63	0	47	36	15	30	29	42
inter-Hut-groups	50	31	8	9	4	3	3	0	—	5
Total	62	52	38	27	12	12	08	15	29	23
Period 5b										
intra-Hut-group 1	—	—	94	42	56	—	—	—	—	64
intra-Hut-group 2	100	—	91	79	78	80	93	86	93	85
inter-Hut-groups	71	63	33	30	33	39	62	8	—	38
Total	85	63	80	56	41	56	77	47	93	60

Note: Figures are calculated as follows. "The number of plates A received from B/the frequency of sharing by B×100" is calculated in all dyads of women. The values of the dyads are average for each kinship index.

Table 10. Meal sharing within and between Hut-groups in B group.

giver	receiver		
	Hut-group 3	Hut-group 4	Hut-group 5
Hut-group 3	16 (7.0)	12 (10.5)	0 (10.5)
Hut-group 4	24 (20.6)	21 (13.8)	10 (20.6)
Hut-group 5	1 (15.0)	11 (15.0)	28 (10.0)

Note: Figures in parentheses indicate the expected frequency of distribution assuming that each adult woman received as often.

groups (Table 9). Because the yield of meat, caterpillars and agricultural food in Period 5b was quite larger than that in Period 5a and 6 (meat, 0.22 kg / person / day in Period 5a and 6, 0.76 kg in Period 5b; caterpillars, 0.01 kg and 0.07 kg; agricultural food, 0.18 kg and 0.39 kg), the number of shared portions increased in Period 5b (Table 6). The increase in the amount of food and the decrease in the Hut-group size brought about the frequent sharing between Hut-groups in Period 5b.

In B group camp, sharing within each hut-group (among close neighbors and kin) was also frequently observed (Table 10). Sharing was also observed between Hut-group 3

and Hut-group 4, and between Hut-group 4 and Hut-group 5. Sharing of F34 and F35 who belong to Hut-group 4 is curious. Although sisters, and were equally kin to the other hut-group members, their sharing partners were quite different. F35 mainly shared with Hut-group 3 (among 36 times of the sharing between Hut-group 3 and Hut-group 4, 27 involved F35), whereas F34 shared with Hut-group 5 (among 21 times between Hut-group 4 and Hut-group 5, 16 involve F34). This corresponded to the location of their huts: i.e., F35's hut was near Hut-group 3, F34's hut was near Hut-group 5 (Fig. 2c).

From these analyses, for a woman in a small camp, all other women are her partners for sharing, whereas in a large camp, the location of huts is an important factor in determining the partners. Because hut making is female work, cooking and sharing what she cooks may be regarded as her domain. Kinship is the second factor in the choice of the receivers.

Not only the location of huts but also the approach to a distributor affects meal sharing. When F36 came back to B group camp after about one month absence, F42 (mother of F36's husband), F37 and F38 (sisters of F42) surrounded F36 in front of F42's hut, pleased with her return. F42 soon began cooking for F36 who was hungry because of the long walk from the village. When cooking was finished and F42 was about to share the stew, F37 and F38 returned to their own huts. Because presence at the sharing site is similar to demanding a share, F37 and F38 avoided the proximity, even if the distributor was their sister. Consequently, F37 and F38 received portions from F42. It is rare for the Aka to demand a share directly in word. On the contrary, the receivers avoid showing obvious desire for a share, and respect the choice of the distributor as possible. However, only through making the hut near other women, which inevitably brings about the proximity in the daily life, women show a clear intent to share stew with the neighboring women, as well as the expectation of receiving a share from them.

Aka women sometimes change the location of the hut. This act sometimes results from her intent to change her sharing partners. In Period 5, the huts of Hut-group 1 slightly moved, forming the hut location in Period 6 (Fig. 2a, 2b). Because the huts made in Period 4 already existed, newcomers in Period 5 could not construct huts arranged in a circle. Specially, the hut of M3 and F3 was proximate to a larger number of huts than others among Hut-group 1 in Period 5a. They moved the huts to get rid of this proximity. b. Meal sharing with men⁽¹¹⁾

Men generally gather at *mbanjo*, where they eat stew brought by the husband or son of the cook. There was one *mbanjo* in the camps of Period 3 and 4, but each hut-group had one *mbanjo* in the camps of Period 5 and 6. There were also two *mbanjo* in the camps of Period 1 and 2.

I analyzed with which *mbanjo* women shared meal in the camps of Period 5 and 6. In Period 5a and 6, women generally shared with *mbanjo* of their hut-groups (Table 11). When a large amount of stew was cooked, or the stew contained meat adult women could not eat because of food restriction, they shared with *mbanjo* of other hut-groups. Also, men generally ate at *mbanjo* of their hut-groups (Table 12). In Period 6, men of Hut-group 1 sometimes ate at *mbanjo* 2, because M1 and M2 discussed the death of M5 with the men of Hut-group 2.

In Period 5b, the women rarely shared with *mbanjo* 1, and the men of Hut-group 1 ate at *mbanjo* 2 (Table 11, 12). There were only three women in Hut-group 1. They could not always cook enough to share with the men of Hut-group 1. The men of Hut-group 1

Table 11. Meal sharing with *mbanjo* in Period 5 and 6.

giver	receiver					
	Period 5a		Period 5b		Period 6	
	<i>mbanjo</i> 1*	<i>mbanjo</i> 2	<i>mbanjo</i> 1	<i>mbanjo</i> 2	<i>mbanjo</i> 1	<i>mbanjo</i> 2
Hut-group 1	8	0	1	8	9	2
Hut-group 2	0	27	0	19	7	29

*: *Mbanjo* 1 is *mbanjo* of Hut-group 1, and *mbanjo* 2 is that of Hut-group 2.

Table 12. *Mbanjo* where men ate meals in Period 5 and 6.

	Period 5a		Period 5b		Period 6	
	<i>mbanjo</i> 1	<i>mbanjo</i> 2	<i>mbanjo</i> 1	<i>mbanjo</i> 2	<i>mbanjo</i> 1	<i>mbanjo</i> 2
Hut-group 1 men	10	3	2	30	12	9
Hut-group 2 men	0	38	0	30	3	72

generally gathered at *mbanjo* 2. Thus, men's sharing partners were not permanent. The men flexibly change sharing groups at *mbanjo* with the circumstances, such as camp size.

DISCUSSION

I. Food Sharing and Ownership

Food sharing cannot be considered independent of food ownership. The concept of "possession" among the hunter-gatherers has been discussed (Dowling, 1968; Ingold, 1986). These discussions indicated that the simple dichotomy between "private property" and "common property" may not be enough to analyze "possession" of the hunter-gatherers. Only the exploration of the process from the food procurement to consumption can reveal the nature of "possession" among hunter-gatherers. In the hunter-gatherer societies, "possession" of food is actually observable through food sharing. In this section, I discuss Aka food "possession" in terms of the role and rights of the owner (*konja*) in food sharing.

There is no food whose *konja* does not exist in the Aka society. *Konja* of the game is the owner of the tool which immobilizes it. *Konja* of honey is the one who finds the beehive (Kitanishi, 1996). *Konja* of plant food is the one who carried it back to camp. *Konja* of stew is the one who contributed the most valuable ingredient, meat in principle. Sometimes, *konja* does not coincide with the actual hunter, collector, or the cook.

Konja is not the exclusive consumer of the food. Dowling indicated that "the rights and prerogatives entailed in ownership are primarily those of performing the distribution, not of deciding whether or not the animal will be distributed" (1968: 505). This holds true for the food sharing of the Aka. I suppose that performing the sharing is the choice of who receive which parts and how much amount of food.

In the Aka, *konja* has limited choice of whether food is shared or not and how many

persons receive it, because *konja* must consider the amount and quality of food. When *konja* has more than 20 kg of meat, he always shares it. Among the !Kung Bushman and the Aka in Lobaye, very small animals are often not shared, or given away (Marshall, 1976; Bahuchet, 1990). The same was seen among the Aka of Linganga-Makaou.

Except for the first distribution of meat, *konja* of food is not forced to share it to a certain person. Considering the camp size, kinship and proximity, *konja* determines the receivers. The choice of the receivers and the social relationship in the camp will be discussed in the next section.

Camp members show consideration for the leadership of *konja* in the sharing. When *konja* is absent, sharing is postponed until the evening of the day at least in the second distribution of meat. Even *konja*'s wife or mother rarely takes on the *konja* role without the approval of *konja*. Also, camp members seldom force *konja* to share food with them. They generally avoid obviously wanting to be shared, leaving the decision to *konja*.

Food is not left unshared for a long time. When the proper *konja* is absent overnight in the second meat distribution or for a few hours in meal sharing, the close relative of *konja* performs the sharing. Honey is, however, the only exception. A beehive is often left at the tree for several days or weeks after finding it. This is because honey can be "preserved" in the beehive.

Even if *konja* is present at the camp, other person sometimes performs the sharing. Because of the sexual division of labor, male *konja* of meal cannot share it at cooking site. In such a case, the distributor always gives to *konja* a larger amount of food than others. When *konja* is absent at the honey collecting site, a part of honey is always brought back to the camp for *konja* (Kitanishi, 1996). When *konja* of honey is absent for several days, camp members generally postpone collecting his honey until his return. I, however, observed that camp members collected honey before the return of *konja* because of the shortage of food in the camp. Their collection was justified by the sharing with *konja*'s wife. In this case, two principles, that close kin substitutes *konja* role in a *konja*'s absence, and that *konja* always receives a part of food when he does not perform the distribution, were applied at the same time. Among the !Kung Bushmen, if the arrow owner (owner of meat) is elsewhere, the hunter saves a portion of the biltong for him (Lee, 1979). The owner can exercise his right even in his absence probably because biltong can be preserved.

When *konja* can not or does not share food directly by the circumstances, he always receives a part of food. This rule can be regarded as actualizing *konja*'s right of performing sharing in another way. *Konja* rarely eats up received food by himself. For instance, male *konja* of meal receives a plate with a large amount of stew, takes it to *mbanjo* and eats together with other men.

Why must a certain person be indicated as *konja*, although his role is only performing sharing? If food is "common property" of camp members, such a "complicated" process of sharing is not necessary. The case that the person who should perform the sharing disappeared reveals the meaning of the existence of *konja* in the sharing. Such confusion arises only when the person other than the Aka participated in sharing, because sharing rules are not understood. When many Aka helped a cultivator carry a large canoe out of the forest, his wife served a meal. She placed two large pots filled with stew in front of the Aka helpers, and left there. They at once ran to the pots to get as much share as possible. Those who were late complained that they could not get any.

In the distribution of food whose *konja* abandons the choice of its receivers, there are unspecified several potential receivers. In such a case, food is “first come, first served.” The persons around there can get it without concern of others. This means that no social relationship emerges among them in this distribution. According to the Aka “possession” of food, the food whose *konja* abandons the choice of its receiver is similar to the food whose owner does not exist: to the wild food in the forest.

In the food sharing of the Aka, the performance of sharing based on *konja*'s own choice of receivers creates the social relationship between *konja* and the specified receivers. I believe *konja* is the key concept for the Aka to bring about such an asymmetrical relationship: the giver and the receiver.

The role of *konja* in the first distribution of meat is, however, considerably different from that in other sharing. Because the first distribution of meat is rule-governed and obligatory, *konja* has no choice. The first distribution of meat can be regarded as the actualization of the ownership established through the process of hunting (Ingold, 1986; Kitamura, 1996). An asymmetrical relationship between the giver and the receiver can be created only by sharing in informal way (Harako, 1976; Ichikawa, 1983) and “spontaneous gifts” (Imamura, 1993). When a close female relative of *konja* was absent in the net hunting, the first distribution was done by some other woman, then the remaining meat was taken to *konja* at the camp. This indicates that it is not always necessary for *konja* to exist in the first distribution.⁽¹²⁾

II. Food Sharing and the Social Relationship among the Camp Members

In the Aka of Linganga-Makaou, the change in the camp size and composition caused by mobile camp members affects the partners of the sharing, although sometimes food is frequently given and received among comparatively fixed members. Ingold (1988) indicated that in hunter-gatherer societies, food sharing is based on “face to face” relationship in the intimate social group, rather than on positions in a rule-governed “social-structure.” The Aka food sharing is rule-governed only in the first distribution of meat. From the next stage, the responsible person for sharing must choose receivers. *Konja* reaffirms social relationships through the choice of receivers in every sharing.

Bahuchet (1985, 1990) indicated that in the Aka of Lobaye, the second distribution of meat was kinship-based. Among the !Kung Bushmen, the owner must share a part of meat with his parents and his wife's parents in the second distribution (Marshall, 1976). In the Central Kalahari Bushman, the second distribution is made among the close relatives (Imamura, 1993). In the second meat distribution of the Aka of Linganga-Makaou, *konja*'s or his wife's parents present at the camp should receive some meat. However, they do not have the priority. Even I received almost the same amount of meat as other camp members (Kitanishi, 1996). Even if *konja* frequently shares her stew with some close relatives, this simply means that they are intimate, and that this familiar relationship is maintained or reinforced by sharing. These suggest that in Linganga-Makaou, kinship is the one of promoters in sharing, but the actual sharing is mainly determined by the circumstances on the spot.

In contrast, in the village camp of Linganga-Makaou, the second distribution is partly governed by kinship. About 300 Aka at the most live in several village camps around the cultivator village. When an Aka man procures an animal in the village camp, he

sometimes shares it with not only his camp members but also his wife's parents staying in the other village camp. In the forest camp, where the Aka always associate with a limited number of camp members, to get along well with all camp members is important in a daily life. In contrast, in the village camps, *konja* must choose a limited number of receivers from many residents, and kinship affects his choice.

Imamura (1996) indicates that for the Central Kalahari Bushmen, one's presence at the cooking place meant he or she expected to receive food. Anybody who judged oneself not entitled to food left. In Imamura's study area of the Central Kalahari Bushmen, there are as many as 600 Bushmen, much more than the Aka I studied. This is probably the reason why food sharing is separated from residence proximity for the Central Kalahari Bushmen. I would like to analyze such difference in food sharing and social relationship between the isolated and open groups in future.

For the Aka, to live in the same camp with other Aka means that there is the possibility to share food with each other. But the tendency of *konja* choice of receivers varies with the kinds of food. It can be said that more highly appreciated food is shared with a larger number of persons inclusively. Meat is shared among all the camp members, because all camp members are interested in it. Stew is shared among neighbors and intimate persons, because it attracts camp members less than large meat. Sharing of a large amount of plant food is somewhere between that of meat and stew.

There is a large difference in meal sharing between the Aka and the Mbuti. As in Linganga-Makaou, the Aka women in Lobaye and Ibenga frequently share the stew (Bahuchet, 1990; Takeuchi, 1995a). The Mbuti women share meals with men gathered at the central hut in the camp and with a limited number of women they are close with. This may indicate that only the integration of men is stressed by meal sharing of the Mbuti, whereas the bond between women is weakly expressed.

In contrast, Aka women form close relationship with the camp members through sharing of meal, unprocessed plant food and meat from net hunting. The difference in the food sharing and the social relationship in the camp would have some relation to the difference in the camp composition and social structure. Virilocal residence is major in the Mbuti. Patrilineally related men have central role in the hunting and form the core of a residential group (Ichikawa, 1986). In the Aka, the virilocal residence and uxorilocal residence are half and half. This is still to be studied in detail, not only with the Aka and Mbuti but also other hunter-gatherer societies.

ACKNOWLEDGMENTS This study was financed by the Ministry of Education, Culture and Science, Japan (Monbusho International Scientific Research Program Nos. 02041034, 04041062 and 06041046). Professor M. Ichikawa, Mr. R. Hanawa and Miss. K. Komatsu of the Center for African Area Studies, Kyoto University and Professor H. Terashima of Kobe Gakuin University gave me great help and kind advice both in the field and in Japan. Professors J. Itani, T. Nishida, J. Tanaka and members of Human Evolution Studies, Kyoto University made valuable comments. Drs. J. Dinga-Reassi and A. A. Ndinga-Makanda, the former Directors of Direction de la Cooperation Scientifique et Technique, helped me in carrying out my study. Mr. P. Ohlin and Mrs. D. Ohlin of Impfondo evangelical mission gave me a hospitable reception. The Aka and the Ikenga friends and S. Ngongo-Gbendo provided me with much information about their life and every convenience in the fields. To these persons, I make grateful acknowledgments.

NOTES

- (1) In the previous paper, I called the slash-and-burn cultivators in the Linganga-Makaou village "Kaka" (Kitanishi, 1994, 1995). But "Kaka" was a word used by the colonial administration and the "Kaka" living in upper Motaba speak several kinds of language. The autochthonous name of the people in Linganga-Makaou is Ikenga (Kitanishi, 1996).
- (2) In this paper, a group consisting of a couple and their unmarried children is called a "family." There is no word which means "family" in the Aka.
- (3) Italics denote the Aka language. Phonetic transcription is, however, not always accurate. The prefix and stem are divided by a period. *Kombeti* has a few senses. First, it denotes an elder, but elder brother and sister in particular. Second, it denotes a central person in a camp. Although *kombeti* is respected as a central person in a camp, he has no special rights.
- (4) Bahuchet (1985) and Takeuchi (1995a) reported the residential arrangements of the Aka in Lobaye of southern Central African Republic and in Ibenga of northeastern Congo. In Lobaye, the Aka camp consisted of about 25 persons. Several camps merged into a larger camp of about 100 persons in the dry season, to hunt with nets. Bahuchet (1985) called this group of 100 persons "bande régionale," whose members owned the territory and road from the cultivator's village to the common forest. In Ibenga, the group consisting of 20-30 persons, which Takeuchi called a "domestic group," was a unit of the residential group. Several domestic groups gather in the forest forming a larger group (60-100 persons) to practice net hunting. These residential groups are quite different from that in Linganga-Makaou. These variations in the Aka residential groups will be analyzed with the data collected in future extensive survey.
- (5) The rules of the first distribution were described by Bahuchet (1985), Takeuchi (1995a) and Kitanishi (1996) in detail. However, these rules are not the same throughout the region.
- (6) The net owner is not always a specific person. Occasionally, the wife or mother of the owner also asserts that they are *konja*. Several old nets are sometimes undone and woven again into a net. Men other than the net owner occasionally weave it to extend it. However, in the actual sharing, only a woman who is a close relative of one of the owners leads game sharing.
- (7) Only mammals are included. Reptiles (such as land tortoises) and birds are not.
- (8) In Period 4-6 of M group and in B group, I observed the second distribution of 85 % of total hunted meat in weight, whereas I did that of less than half in Period 1 and 2 of M group. The second distributions in Period 1 and 2 were not analyzed in this section.
- (9) There was no *mbanjo* in the camp in Period 3. Men usually stayed separately at their huts. When cooking was finished, the husband of the cook took a plate to the center of the camp. Other men saw it and gathered to eat together, then went back to their huts.
- (10) According to the Bahuchet (1990), in Lobaye, men separately ate meal with their wives and children in general.
- (11) Because more than half of the male members left for gun hunting with a villager in the research period of B group, the analysis of meal sharing with men was omitted.
- (12) In this paper, only *konja* of food is described. The term designates the owner of various tools as well, such as the ax and the spear. According to Bahuchet (1990), it was also used for the leader of ceremony or of singing, as in *konja-lembo*, "song leader," and *konja-lango*, "camp leader" (synonym for *kombeti* in Linganga-Makaou). He also said that *be.dio* "spirits" were thought of as *konja* "owners" of the forest. Further examination of the use of *konja* in a wider context is necessary for a comprehensive understanding of the concept of *konja*.

REFERENCES

- Bahuchet, S. 1985. *Les Pygmées Aka et la Forêt Centrafricaine*. SELAF, Paris.
- 1990. Food sharing among the Pygmies of Central Africa. *African Study Monographs*, 11 (1): 27-53.
- Bahuchet, S. & J. M. C. Thomas 1986. Linguistique et histoire des pygmées de l'ouest du bassin Congolais. *Sprache und Geschichte in Afrika*, 7 (2): 73-103.
- Cloarec-Heiss, F. & J. M. C. Thomas 1978. *L'Aka, langue bantoue pygmées de Mongoumba (Centrafrique) Introduction a l'étude linguistique. Phonologie*. SELAF, Paris.
- Demesse, L. 1980. *Techniques et Economies des Pygmées Babinga*. Institut d'Ethnologie, Paris.
- Dowling, J. 1968. Individual ownership and the sharing of game in hunting societies. *American Anthropologist*, 70(3): 502-507.
- Guthrie, M. 1967-1970. *Comparative Bantu*, 4 vols. Gregg Press, Hants.
- Harako, R. 1976. The Mbuti as hunters: A study of ecological anthropology of the Mbuti Pygmies (I). *Kyoto University African Studies*, 10: 37-99.
- Ichikawa, M. 1983. An examination of the hunting-dependent life of the Mbuti Pygmies, Eastern Zaire. *African Study Monographs*, 4: 55-76.
- 1986. Ecological bases of symbiosis, territoriality and intra-band cooperation of the Mbuti Pygmies. *Sprache und Geschichte in Afrika*, 7 (1): 161-188.
- Imamura, K. 1993. Cooperation and sharing among the Central Karahari San: Observation on the women's subsistence activities (in Japanese). *Journal of African Studies*, 42: 1-25.
- 1996. The modest feast: food distribution of Bushman hunter-gatherers (in Japanese). In (J. Tanaka, K. Kakeya, M. Ichikawa & I. Ohta eds.) *Anthropology of Nature-dependent Societies II*, pp. 51-80, Academia Syuppankai, Kyoto.
- Ingold, T. 1986. *The Appropriation of Nature: Essays on Human Ecology and Social Relations*. Manchester University Press, Manchester.
- 1988. Notes on the foraging mode of production. In (T. Ingold, D Riches & J. Woodburn eds.) *Hunters and gatherers*, pp. 269-285, Berg Publishers Limited, Oxford.
- Kaplan, H. & K. Hill 1985. Food sharing among Ache foragers: test of explanatory hypotheses. *Current Anthropology*, 26 (2): 223-246.
- Kaplan, H., K. Hill, K. Hawkes & A. Hurtado 1984. Food sharing among Ache hunter-gatherers of eastern Paraguay. *Current Anthropology*, 25 (1): 113-115.
- Kitamura, K. 1996. Egalitarian societies and the notion of nostalgia (in Japanese). *Journal of African Studies*, 48: 19-34.
- Kimura, D. 1992. Daily activities and social association of the Bongando in central Zaire. *African Study Monographs*, 13 (1): 1-33.
- Kitanishi, K. 1994. The exchange of forest products (Irvingia nuts) between the Aka hunter-gatherers and the cultivators in northeastern Congo. *Tropics*, 4 (1): 79-92.
- 1995. Seasonal changes in the subsistence activities and food intake of the Aka hunter-gatherers in northeastern Congo. *African Study Monographs*, 16(2): 73-118.
- 1996. Variability in the subsistence activities and distribution of food among different aged males of the Aka hunter-gatherers in northeastern Congo. *African Study Monographs*, 17(1): 35-57.
- Leacock E. & R. Lee 1982. Introduction. In (E. Leacock & R. Lee eds.) *Politics and History in Band Societies*, pp. 1-20, Cambridge University Press, Cambridge.
- Lee, R. 1979. *The !Kung San: Men, Women, and Work in a Foraging Society*, Cambridge University Press, Cambridge.
- 1988. Reflections on primitive communism. In (T. Ingold, D Riches & J. Woodburn eds.) *Hunters and gatherers*, pp. 252-268, Berg Publishers Limited, Oxford.
- Marshall, L. 1976. Sharing, talking, and giving: relief of social tensions among the !Kung. *Africa*.

31:231-249.

- Rousseau, J. J. 1754. *Discours sur l'Origine et les Fondements de l'Inégalité parmi les Hommes* (1984, translated by N. Takeuchi). Hakusuisya, Tokyo.
- Sahlins, M. 1972. *Stone Age Economics*. Adline Publishing Co., Chicago.
- Service, E. 1966. Foundations of Modern Anthropology Series 6: *The Hunters*. Prentice-Hall, Inc., Englewood Cliffs.
- Takeuchi, K. 1994. Dietary avoidance among the Aka hunter-gatherers, northeastern Congo (in Japanese). *Journal of African Studies*, 44: 1-28.
- 1995a. Ritual aspects and pleasure in hunting activities: Cooperation and distribution in the net-hunting activities of Aka hunter-gatherers in northeastern Congo (in Japanese). *Journal of African Studies*, 46: 57-76.
- 1995b. Subsistence hunting in African tropical forest: Hunting techniques and activities among the Aka hunter-gatherers, Northeastern Congo (in Japanese). *Zoo-archaeology*, 4: 27-52.
- Tanno, T. 1981. Plant utilization of the Mbuti Pygmies: With special reference to their material culture and use of wild vegetable foods. *African Study Monographs*, 1: 1-53.
- Terashima, H., M. Ichikawa & M. Sawada 1988. Wild plant utilization of the Balese and the Efe of the Ituri forest, Republic of Zaire. *African study Monographs*, Supplementary Issue, No. 8.
- Thomas, J. M. C. & S. Bahuchet, 1983-. *Encyclopédie des Pygmées Aka*. 14 vol. SELAF.
- Wiessner, P. 1982. Risk, reciprocity and social influences on !Kung San economies. In (E. Leacock & R. Lee eds.) *Politics and History in Band Societies*, 61-84, Cambridge University Press, Cambridge.
- Woodburn, J. 1982. Egalitarian societies. *Man (N.S.)*, 17: 431-451.

——— Accepted January 20, 1998

Author's Name and Address: Koichi KITANISHI, Faculty of Education, Yamaguchi University, 1-1677, Yosida, Yamaguchi, 753-8513, JAPAN.

Appendix 1. The second distribution of meat in each period (kg).

M group		Period 3						receiver							Total						
		F17	F1	F14	F2	F20	F7														
<i>konja</i>																					
M2		2.24	3.05	1.95	<u>6.38</u>	2.00	3.38									19.00					
Note: Underlined figures indicate the weight of meat remaining with <i>konja</i> .																					
Period 4		receiver						Total													
		F1	F5	F18	F3	others	Total														
<i>konja</i>																					
M5		5.85	<u>15.56</u>	0.00	13.73	9.86	45.00														
M1		<u>9.12</u>	2.55	7.40	4.71	5.22	29.00														
M1		<u>3.80</u>	2.15	0.00	5.25	2.90	14.10														
M1		<u>23.10</u>	9.00	0.00	9.90	5.00	47.00														
Period 5 and 6		receiver															Total				
		Hut-group 1							Hut-group 2							other unknown	Total				
		F1	F6	F3	F18	F5	F12	F17	F2	F10	F21	F20	F23	F22	F15	F11	F4	F9	other unknown	Total	
<i>konja</i>																					
Period 5a																					
M4		0	7.02	0	0	0	0	0	0	0	6.25	3.00	0	0	0	0	<u>0.00</u>	0	4.00	0	20.27
M4		1.66	0	0	0	0	0	0	0	0	0	0	0	0	0	3.33	<u>3.35</u>	1.66	0	0	10.00
M5		0	0	0	0	<u>1.00</u>	0	0	0	0	0	0	0	0	0	0	0	0	0	0	1.00
F21		0	0	0	0	0	0	0	0	0	<u>0.65</u>	0	0	0	0	0	0	0	0	0	0.65
M20		0	0	0	0	0	0	0	0	0	<u>0.90</u>	0	0	0	0	0	0	0	0	0	0.90
F22		0	0	0	0	0	0	0	0.75	0	0.75	0	0	<u>1.65</u>	0	0	0	0	0	0	3.15
F22		0	0	0	0	0	0	0.85	0	0	0	0	0	<u>0</u>	0	0	0	0	0	0	0.85
F15		0	0	0	0	0	0	0	0	0	0	0	0	0	<u>1.25</u>	0	0	0	0	0	1.25
Period 5b																					
M1		<u>14.50</u>	0	-	-	-	3.50	-	-	-	0	-	0	0	10.00	-	9.50	0	19.00	56.50	
M9		2.00	12.10	-	-	-	8.70	-	-	-	6.00	-	0	0	16.60	2.70	-	<u>18.40</u>	4.20	0	70.70
Period 6																					
M15		9.67	8.75	0	0	0	0	0	2.53	0	0	0	0	0	<u>10.17</u>	3.00	0	0	0	6.75	40.87
M9		0	3.50	0	0	0	20.77	0	2.00	1.37	0	0	0	0	1.42	9.96	<u>6.01</u>	1.42		58.20	

B group

	receiver										Total
	Hut-group 3			Hut-group 4			Hut-group 5			other	
	F40	F33	F31	F35	F34	F41	F42	F37	F38		
konja											
M37	0	0	4.05	0	2.70	0	0	6.20	3.85	3.20	20.00
M31	1.50	0	8.50	0	0	1.50	0	0	0	0	11.50
Total	1.50	0	12.55	0	2.70	1.50	0	6.20	3.85	3.20	31.50

Appendix 2. The sharing of unprocessed plant food in Period 5 and 6.

giver		receiver															
		Hut-group 1							Hut-group 2								
		F1	F6	F3	F18	F5	F12	F17	F2	F10	F21	F20	F23	F22	F15	F11	F4
Period 5a																	
wild yam	F2	○	×	×	×	○	×	×	-	×	×	×	×	×	×	×	×
wild yam	F2	○	○	×	×	×	○	×	-	×	○	×	×	○	×	×	×
cassava	F17*	○	○	×	×	○	-	-	○	×	○	×	×	○	×	×	○
cassava	F2*	○	×	-	×	○	×	×	-	×	×	○	×	○	×	×	○
Period 5b																	
cassava	F11	×	○	-	-	-	×	-	-	○	-	×	○	×	-	-	×
cassava	F9	×	○	-	-	-	×	-	-	×	-	×	○	×	×	-	-
Period 6																	
cassava leaves	F21	×	○	×	×	×	○	×	×	×	-	×	×	×	×	×	○
oil palm	F21	×	×	×	×	×	×	○	×	×	-	×	×	○	×	×	○
oil palm	F2*	○	○	-	×	×	×	×	-	×	×	○	×	○	×	○	○
oil palm	F17*	○	×	×	×	×	-	-	×	×	×	○	×	○	×	×	×

○: Received.

×: Not received.

-: Absent or giver.

*: Women who shared agricultural food carried by their daughters did not shared with their daughters (carriers). These mothers-daughters are excluded from the analysis.

Appendix 3. Meal sharing in each period.

giver	receiver											
	F17	F1	F14	F2	F20	F7	<i>mbarjo</i>	adult men	children	total number	total times*	women times**
F17	-	5	6	6	6	6	5	0	0	34	8	7
F1	0	-	2	2	2	2	3	0	0	11	3	2
F14	3	2	-	1	3	3	0	0	0	12	3	3
F2	3	4	3	-	3	4	5	0	3	25	5	5
F20	1	1	1	1	-	1	0	0	0	5	2	1
F7	4	4	4	6	5	-	6	1	2	32	8	6

*: Total frequency of cooking, including when stew was not shared.

**: Total frequency of meal shared with at least one adult woman. These are denominators of the proportion calculated in Table 9.

Period 4

giver	receiver							total number	total times	women times
	F1	F5	F18	F3	<i>mbanjo</i>	adult men	children			
F1	—	5	2	6	7	4	4	28	6	6
F5	5	—	4	4	7	7	0	27	6	6
F18	3	4.5	—	2	2	3	0	14.5	5	5
F3	7	6	5	—	10	4	6	38	10	10

Period 5a

giver	receiver																			total number	total times	women times		
	Hut-group 1							Hut-group 2																
	F1	F6	F3	F18	F5	F12	F17	F2	F10	F21	F20	F23	F22	F15	F11	F4	F9	<i>mbanjo</i>	adult men	children	others			
F1	—	1	0	0	1	0	0	0	0	0	0	0	0	0	0	0	0	1	0	0	0	3	2	1
F6	3	—	2	0	3	0	2	3	0	0	0	0	2	0	0	1	0	2	1	0	0	19	8	4
F3	2	4	—	1	3	1	4	2	0	0	0	0	0	0	0	0	0	3	1	2	0	23	4	4
F18	1	1	1	—	2	0	1	1	0	0	0	0	0	0	0	0	0	0	2	0	0	9	2	2
F5	1	1	0	0	—	0	0	0	0	0	0	0	0	0	0	0	0	0	0	0	0	2	1	1
F12	0	1	2	0	0	—	2	1	0	0	0	0	0	0	0	0	0	0	1	2	0	9	3	3
F17	2	1	2	0	2	1	—	2	0	0	0	0	0	0	1	0	0	2	1	1	0	15	3	3
F2	2	2	1	1	1	0	2	—	0	0	0	0	0	0	0	0	0	0	0	0	0	9	2	2
F10	0	0	0	0	0	0	0	0	—	4.5	0.5	1.25	1.25	0.25	2.25	1	5	4	0	0	0	20	6	5
F21	0	0	0	0	0	0	0	0	—	1.5	2	1	3	3	2	3	3	4	3	0	0	28.5	7	5
F20	0	0	0	0	0	0	0	0	0	—	1	—	0	1	0	1	1	1	1	0	0	7	1	1
F28	0	0.17	0	0	0	0	0	0	0.17	1.17	0	—	3	1.17	1.17	0	1	0	0	0	0	7.85	4	4
F22	0	0	0	0	0	0	0	0	0	0	0	0	—	0	0	0	0	0	0	0	0	0	0	0
F15	1	1	0	0	0	0	0	0	0	2	0	0	4	—	4	1	3	3	0	0	0	19	4	4
F11	0	0	0	0	0	1	0	0	2.5	6	1	3	7	5	—	2	5	6	0	0	0	38.5	7	7
F4	0	0.5	0	0	0	0	0	0	1	1	0	2	0.5	1	—	2	2	1	0	0	0	11	4	2
F9	0	3	0	0	0	0	0	1	5.5	5.5	4.5	2	5	5	5.5	4	—	10	1	1	0	53	11	8
men	0	0	0	0	0	0	0	0	0	0	0	0	0	0	0	0	0	0	—	0	0	0	1	0
child	0	0	0	0	0	0	0	0	2	1	0	5	0	0	0	0	0	3	0	0	10	21	9	7
others	1	1	1	0	1	1	1	1	0	0	0	0	0	0	0	0	0	0	0	0	0	7	1	1

Period 5b

giver	receiver											total number	times	women times		
	Hut-group 1			Hut-group 2												
	F1	F6	F12	F21	F23	F22	F15	F11	F9	<i>mbanjo</i>	child	adult men	others			
F1	—	3	1	0	0	0	0	0	0	0	0	0	1	5	4	3
F6	7	—	5	3	1	6	4	2	4	5	0	1	4	42	8	8
F12	3	3	—	4	1	5	1	6	2	4	0	0	0	29	6	6
F21	1	4	4	—	6	6	5	5	6	4	3	0	2	46	7	7
F23	0	2	0	4	—	4	3.5	2.5	4	2	0	0	1	23	4	4
F22	2	2	3	3	3	—	3	3	3	3	0	0	1	26	3	3
F15	1	3	0	4	2	4	—	3	3	2	1	0	0	23	4	4
F11	0	2	3	3	3	3	3	—	2	3	0	0	1	23	3	3
F9	2	4	3	5	5.5	4.5	5	7	—	5	3	0	2	46	8	8

Period 6

giver	receiver																				total number	total times	women times	
	Hut-group 1										Hut-group 2													
	F1	F6	F3	F18	F5	F12	F17	F2	F10	F21	F20	F23	F22	F12	F11	F4	F9	mbanja	adult men	children				others
F1	-	2	0	0	1	0	1	1	0	0	0	0	0	0	0	0	0	2	2	2	0	11	8	3
F6	1	-	1	0	1	0	0	0	0	0	0	0	0	0	0	0	0	3	1	0	0	7	5	1
F3	0	4	-	6.5	0.5	3	2	6	0	0	0	0	0	0	0	0	0	1	4.66	0	27.7	9	8	
F18	2	3	5	-	6	3.5	1.5	3	0	0	0	0	0	0	0	0	2	4	1	0	31	10	8	
F5	0	0	0	0.5	-	0	0	0	0	0	0	0	0	0	0	0	0	0	0	0	0.5	2	0	
F12	0	3	5	2.5	1	-	3.5	2	0	1	0	0	0	2	1	1	1	1	1	1	0	25	6	6
F17	1	2	0	3	0	2.5	-	4	0	1	0	0	2	0	1	2	2	3	0	2	0	25.5	7	7
F2	3	3	4	0.5	2.5	1.5	2.5	-	0	0	1	0	2	0	1	1	1	2	2	1	0	28	5	4
F10	0	0	0	0	0	0	0	0	-	2	0	0	2	0	1	0	2	2	0	0	0	9	3	2
F21	0	0	0	0	0	0	2	0	0	-	3.5	1	1	2	2	1	2	3	0	0	0	17.5	9	6
F20	0	0	0	0	1	0	1	1	0	5	-	3	0	1	1	2	4	3	2	2	0	26	6	5
F23	0	0	0	0	0	0	0	0	0	0	0	0	-	1	0	0	0	0	0	0	0	1	1	1
F22	0	1	0	0	0	0	0	0	0	0	1	1	-	0	1	1	1	2	0	0	0	8	3	1
F15	0	4	0	0	0	1	0	0	0	1	1	3	2	-	5	2	3	8	2	1	0	33	8	6
F11	0	1	0	0	0	1.5	1	0	2.5	3	3	2.5	7	4.5	-	7	7	4	0	0	0	44	8	7
F4	1.42	1	0.25	1.17	0.17	0	1.42	1.25	1	1.33	3.17	1.25	3.25	0.25	2.75	-	4.33	5	3	3	1	36	11	8
F9	1	1	0	1	0	0	1	1	3	3	4	1	4	1	3	6	-	9	1	6	0	46	13	7
men	0	0	0	0	1	0	0	0	0	0	0	0	0	0	0	0	0	1	0	0	0	2	1	-
child	0	1	0	0	0	0	0	0	1.25	1	0	3.58	2.33	3	2.25	3	1	3	1	4.25	0	26.7	7	-

B group

giver	receiver															total number	total times	women times
	Hut-group 3				Hut-group 4				Hut-group 5									
	F39	F32	F31	F32	F35	F34	F41	F36	F42	F37	F38	F39	adult men	children	others			
F39	-	1	1	0	0	0	0	0	0	0	0	0	2	0	0	4	5	1
F32	3	-	5	0	4	0	1	0	0	0	0	0	6	3	4	26	10	5
F31	2	4	-	1	5	1	1	0	0	0	0	0	9	2	8	33	10	5
F32	0	0	0	-	0	0	0	0	0	0	0	0	0	0	0	0	0	0
F35	3	7	8	0	-	5	4	0	0	0	0	0	6	1	3	37	8	8
F34	0	2	3	0	5	-	6	0	3	2	5	1	3	3	0	33	7	6
F41	0	0	1	0	0	1	-	0	0	0	0	0	1	0	0	3	1	1
F36	0	0	0	0	0	0	0	-	0	0	0	0	0	0	0	0	0	0
F42	0	0	0	0	0	2	2	1	-	3	4	1.5	8	2.5	0	24	7	4
F37	0	0	0	0	1	1	0	0	1	-	1	0.5	1	0.5	0	6	2	1
F38	0	0	1	0	1	3	1	0	3	3	-	0.25	3	1.75	0	17	4	4
F39	0	0	0	0	0	0	0	0	0	1	0	-	0	1	0	2	1	1
men	0	0	0	0	0	0	0	0	0	0	0	0	-	0	0	0	1	-
child	0	0	0	0	0	0	0	0	3	2	2	1.5	2	1	1	12.5	5	-