

A Proposal for Energy Extracting Float

Kesayoshi Hadano¹⁾, Pallav Koirala²⁾, Makoto Watanabe²⁾

1) Department of Civil and Environmental Engineering, Yamaguchi University

2) Graduate School of Engineering, Yamaguchi University
 Ube, Yamaguchi, Japan

ABSTRACT

We propose a floating vessel which extracts energy from wind or tidal flow through its pitching motion. In order to extract significant energy, a considerable inclination of the vessel is needed. This is achieved through the rotation of flat plates which face towards the flow of the wind or tidal current at twice the natural oscillation of pitching motion. This in turn, creates the desired pitching motion of the vessel. In this paper, the dynamics of the pitching motion of the vessel and its stability are studied along with the dynamics of the rotating plates.

KEY WORDS: Floating vessel; rotating plate; oscillation; drag force.

INTRODUCTION

A rising demand for energy coupled with the problem of environmental pollution, has led to investigations into potential new energy sources. In the previous paper, Hadano et. al. (2004) had proposed a wave energy conversion device (Fig. 1) with a movable body which transferred wave energy into a rotational motion of a shaft using a float and counterweight. These were connected to a pulley set above the waterline by a wire. The use of wire, a flexible material, is not only more economical but also helps to avoid the problems related to structural strength common in most types of movable body systems.

We investigate the system that extracts the energy of the tidal currents in this paper through the application of the above mechanism in a floating vessel. Two float-counterweight energy conversion units enclosed within vertical water columns are installed on a large vessel as shown in Fig. 2. The floating vessel is comprised of three chambers. The central chamber houses the mechanical equipment, gearbox and power source. The two chambers on either side are flooded from outside of the vessel through inlets located on the walls in order to increase stability. The vertical motion of the floats, as caused by the pitching motion of the vessel, is utilized to generate electric power. Flat plates fitted at the bottom of the vessel are rotated at a certain velocity through the use of an external power source in order to obtain a pitching motion. The rotating plates may be placed at the top of the vessel producing the same pitching motion by using wind power as opposed to the tidal flow. The dynamics model for the rotation of the

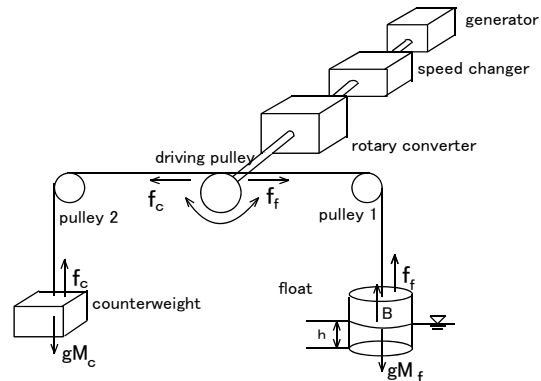

Fig. 1 Schematic diagram of the float type system

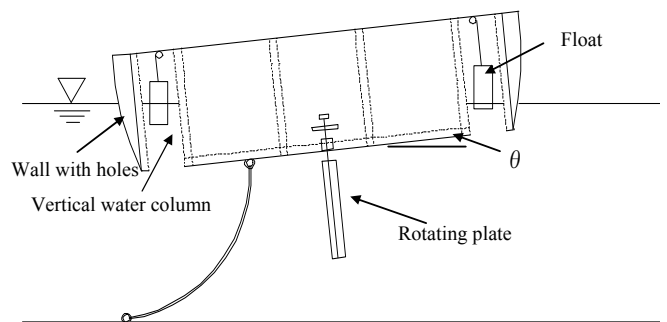

Fig. 2 Floating vessel fitted with floats and rotating plates

plates due to tidal flow and for the oscillation of the floating vessel, have been explained here. The work and torque needed to rotate the plates in the tidal flow to induce the pitching motion of the vessel have been formulated. Numerical methods are used to ascertain time series for the pitching angle and its derivative. We also briefly discuss the stability of the floating vessel taking into account the tensile force of the wire supporting the floats in the vessel's ordinary condition of stability.

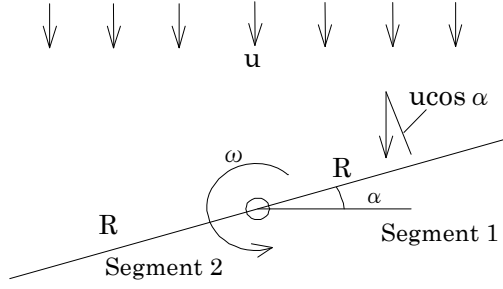

Fig. 3 Water flow and the rotating plate under the floating vessel

DYNAMICS OF THE ROTATING PLATE

Energy is expended in rotating the plates which are fitted at the bottom of the vessel to obtain its pitching motion. The formulation of expressions to calculate the work and torque required to rotate the plates has been presented here. Fig. 3 shows the plan view of an isolated plate with a width of $2R$ and length of l , which rotates at an angular velocity ω about the vertical axis through its center. For simplicity, we assume the flow to be turbulent everywhere around the plate and ignore the effect of the inclination of the vessel on the relative velocity between the flow and the rotating plates.

Initially, at time $t=0$, the plate is set at right angles to the direction of the flow, i.e., its angle of rotation, $\alpha=0$. Calculations of work and torque for $\alpha=0$ to $\pi/2$ are made here, which can be doubled to obtain the work and torque required for a full rotation.

The relative velocity at any point on the rotating plate located at a distance r from its center can be expressed as

$$\Delta V_{\tau} = u \cos \alpha + r\omega \quad (1)$$

$$\Delta V_{\tau} = u \cos \alpha - r\omega \quad (2)$$

where u is the flow velocity. Eq. 1 is applicable in segment 1 of the plate and Eq. 2 in segment 2.

When ($0 < \alpha < \pi/2$)

The analyses for segment 1 and 2 of the plate are made separately and combined later.

Computation of Work and Torque for segment 1. This section of the plate experiences an opposing force from the flow. The work required to rotate it is given as

$$P_1 = \sum_i F_i V_i = \sum \left(\frac{1}{2} \rho C_D \Delta V_{\tau}^2 l dr \right) * (r\omega) \quad (3)$$

where F_i : drag force of the flow, ρ : density of water and C_D : coefficient of drag force.

Using Eq. 1 in Eq. 3 we obtain

$$P_1 = \frac{1}{2} \rho C_D l \omega \int_0^R (u \cos \alpha + r\omega)^2 r dr \quad (4)$$

Finally after integration,

$$P_1 = \frac{1}{2} \rho C_D l \omega \left(\frac{1}{2} u^2 \cos^2 \alpha R^2 + \frac{2}{3} u \cos \alpha \omega R^3 + \frac{1}{4} \omega^2 R^4 \right) \quad (5)$$

Computation of the Work and Torque in segment 2. If the tangential component of the relative velocity between the plate and the flow is zero at a distance R/l from the center of the plate, then the work needed to rotate the plate when $R < R/l$ can be written as

$$P_1 = \sum_i F_i V_i = \sum \left(\frac{1}{2} \rho C_D \Delta V_{\tau}^2 l dr \right) * (-r\omega) \quad (6)$$

Substituting V_{τ} from Eq. 2 we get,

$$P_2 = -\frac{1}{2} \rho C_D l \omega \int_0^R (u \cos \alpha - r\omega)^2 r dr \quad (7)$$

If $R > R/l$ (point where the tangential component of the relative velocity lies within the plate), the work required can be expressed as

$$P = -\frac{1}{2} \rho C_D l \omega \int_0^{R_1} (u \cos \alpha - r\omega)^2 r dr + \frac{1}{2} \rho C_D l \omega \int_{R_1}^R (u \cos \alpha - r\omega)^2 r dr \quad (8)$$

The time t_1 , after which the relative tangential velocity at the edge of the plate with respect to the flow will be zero can be written as

$$t_1 = \cos^{-1}(R\omega/u)/\omega \quad (9)$$

From time $t=0$ to t_1 , the total work required to rotate the plate is obtained by combining Eq. 4 and Eq. 7 as follows

$$P = \frac{2}{3} \rho C_D l \omega^2 R^3 u \cos \alpha \quad (10)$$

And the required torque is given as

$$M = \frac{P}{\omega} = \frac{2}{3} \rho C_D l \omega R^3 u \cos \alpha \quad (11)$$

From time $t=t_1$ to $\pi/2\omega$, the total work required is given by combining Eq. 4 and Eq. 8 as

$$P = \frac{1}{2} \rho C_D l \omega \left(u^2 \cos^2 \alpha \cdot R^2 + \frac{1}{2} \omega^2 R^4 \right) - \frac{1}{2} \rho C_D l \omega \left(u^2 \cos^2 \alpha \cdot R_1^2 - \frac{4}{3} u \cos \alpha \cdot \omega R_1^3 + \frac{1}{2} \omega^2 R_1^4 \right) \quad (12)$$

The required torque is given as

$$M = \frac{1}{2} \rho C_D l \left(u^2 \cos^2 \alpha \cdot R^2 + \frac{1}{2} \omega^2 R^4 \right) - \frac{1}{2} \rho C_D l \left(u^2 \cos^2 \alpha \cdot R_1^2 - \frac{4}{3} u \cos \alpha \cdot \omega R_1^3 + \frac{1}{2} \omega^2 R_1^4 \right) \quad (13)$$

When ($\pi/2 < \alpha < \pi$)

The work and torque required to rotate the plate in this case has been calculated by an analysis similar to the previous section.

From $t = \pi/2\omega$ to $t = \pi/\omega - \cos^{-1}(R\omega/u)$

$$P = \frac{1}{2} \rho C_D l \omega \left[u^2 R^2 \cos^2(\pi - \omega t) + \frac{1}{2} \omega^2 R^4 \right] - \frac{1}{2} \rho C_D l \omega \left[u^2 R_1^2 \cos^2(\pi - \omega t) - \frac{4}{3} u \omega R_1^3 \cos(\pi - \omega t) + \frac{1}{2} \omega^2 R_1^4 \right] \quad (14)$$

$$M = \frac{1}{2} \rho C_D l \left[u^2 R^2 \cos^2(\pi - \omega t) + \frac{1}{2} \omega^2 R^4 \right] - \frac{1}{2} \rho C_D l \left[u^2 R_1^2 \cos^2(\pi - \omega t) - \frac{4}{3} u R_1^3 \cos(\pi - \omega t) + \frac{1}{2} \omega R_1^4 \right] \quad (15)$$

And for $t = \pi / \omega - \cos^{-1}(R\omega / u)$ to $t = \pi / \omega$,

$$P = \frac{2}{3} \rho C_D l \omega^2 u R^3 \cos(\pi - \omega t) \quad (16)$$

$$M = \frac{2}{3} \rho C_D l \omega u R^3 \cos(\pi - \omega t) \quad (17)$$

From the above analyses, it is found that the expressions for work and torque contain terms proportional to the second, third and fourth power of R . Therefore it is advantageous to use many plates with a small R rather than a few plates with a large R as the work and torque required to rotate them will be smaller.

DYNAMICS OF THE OSCILLATING VESSEL

As shown in Fig. 4, a floating vessel is located on the surface of flowing water with the velocity u , by mooring. It has a number of flat rotating plates (Fig. 3) set in a row at the bottom. For ease of analysis, the floating vessel is assumed to be rectangular in cross section with a length, width and height respectively of a , b and c . Its mass moment of inertia, I , is given by the following equation.

$$I = \sigma b^3 c a^3 / 12 \quad (18)$$

where σ is the mass density of the vessel.

The moment of inertia of the plane cut by the water surface is given as

$$I_y = b^3 a^3 / 12 \quad (19)$$

If the length and the width of the rotating plates are respectively l and b'/m and there are n number of such plates arranged in a row, then the moment exerted at the base of the vessel due to their rotation can be expressed as

$$M = n \frac{1}{2} \rho C_D u^2 l^2 \frac{b'}{m} |\cos(\omega t)| \cos^2 \theta \quad (20)$$

where m is a variable number which correlates to the width and the number of plates, all other symbols carry the same meaning as described in the previous section. The pitching motion of the floating vessel can be related to the above moment by the following equation.

$$I \frac{d^2 \theta}{dt^2} + \rho g I_y \theta = M = n \frac{1}{2} \rho C_D u^2 l^2 \frac{b'}{m} |\cos(\omega t)| \cos^2 \theta \quad (21)$$

Using Eq. 18 and Eq. 19 in Eq. 21, we obtain the general equation for computing the pitching angle and its derivative, which is given as Eq. 22.

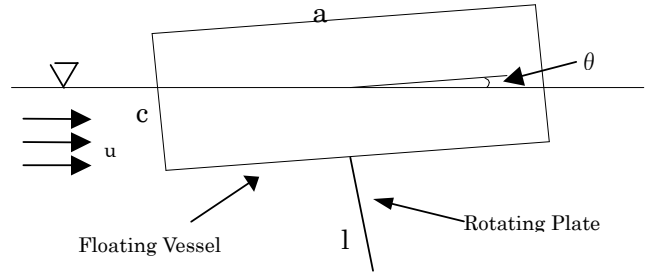

Fig. 4 Dynamics Model of the pitching motion of the floating vessel

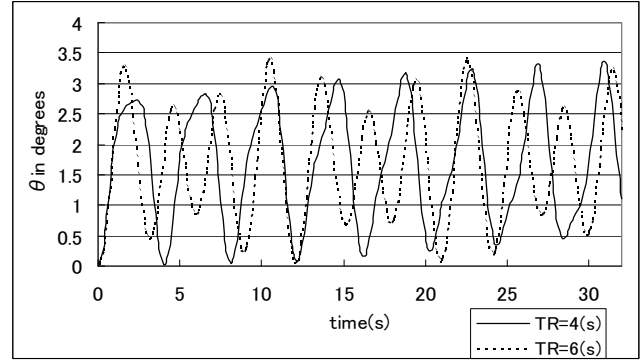

Fig. 5 Time series of pitching motion at $T_R < T_{RR}$

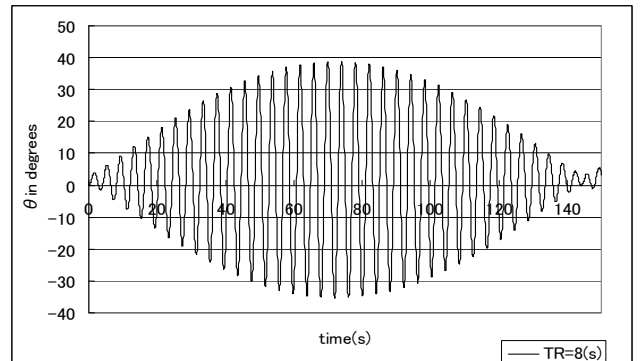

Fig. 6 Time series of pitching motion at $T_R = T_{RR} = 8(s)$

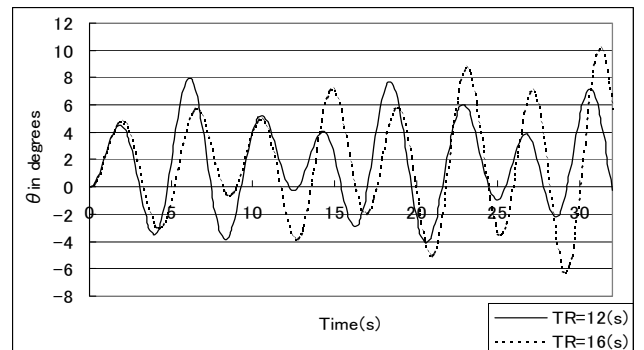

Fig. 7 Time series of pitching motion at $T_R > T_{RR}$

$$\left(\frac{d^2\theta}{dt^2} + \frac{\rho g}{\sigma c}\theta\right) = \frac{6}{a^3 c} \frac{\rho}{\sigma} C_D u^2 l^2 \frac{n}{m} |\cos(\omega t)| \cos^2 \theta \quad (22)$$

$$\text{Initial conditions: } \theta(0) = 0, \frac{d\theta(0)}{dt} = 0 \quad (23)$$

Taking $C_D=1.0$, $u=2\text{m/s}$, $a=10\text{m}$, $b=7\text{m}$, $c=6\text{m}$, $l=5\text{m}$, $n=6$, $m=8$ and $\rho/\sigma=1/0.7$, Eq. 22 has been solved with the Runge-Kutta method to obtain the time series of θ and $d\theta/dt$. Figs. 5~7 show the results of the calculation for different time periods for the rotation of the plate (T_R). T_{RR} is the resonance period of the plate rotation to the pitching motion defined as

$$T_{RR} = 2 T_v \quad (24)$$

Where T_v is the natural period of the pitching motion of the vessel.

From Fig. 5 it can be observed that the pitching angle θ is always positive when $T_R < T_{RR}$. This reflects a phenomenon in which the plates receive the force from the flow before the reverse inclination of the vessel occurs. Fig. 6 has been plotted for $T_R = T_{RR} = 8$ seconds and shows that θ oscillates with varying amplitude in cycles. The maximum amplitude of the oscillation is very high compared to other cases, this implies that the natural frequency of the vessel matches the frequency of the pitching motion at 8 seconds creating a resonance. When $T_R > T_{RR}$ as shown in Fig. 7, the amplitude of θ fluctuates between positive and negative with a larger magnitude towards the positive reflecting the effect of the drag force. The amplitude also varies from cycle to cycle.

STABILITY OF THE FLOATING VESSEL

In the present floating vessel fitted with the float-wire-counterweight energy conversion system, the tensile force of the wire should be included while studying the stability of the vessel. The general condition of stability is given by the following equation.

$$I_y / V > GC \quad (25)$$

where I_y is the minimum moment of inertia of the plane cut by the water line, V is the submerged volume of the vessel and GC is the distance between the center of gravity and the metacenter.

If the wire tensile force in the wire acts at a distance d_2 and the center of gravity is located at d_1 from the bottom of the vessel, then the distance from the bottom of the vessel to its center of buoyancy, d_d , and to the apparent center of gravity of the whole system d_G , can be expressed as

$$d_d = d/2 = V/2ba \quad (26)$$

$$d_G = (Fd_1 + 2\sum f_j d_2) / W \quad (27)$$

where a : length of the vessel, b : width of the vessel, d : height of the vessel, F : weight of the vessel, f_j : tensile force in the wire, W : weight of the vessel including the tensile force in the wire.

Using Eq. 26 and Eq. 27 in Eq. 25, the condition of stability is given as

$$\rho g a b^3 / 12W > (Fd_1 + 2\sum f_j d_2) / W - V / 2ba \quad (28)$$

where ρ : density of water, g : gravity.

Eq. 28 provides a check for the stability of the vessel taking into account the tensile force in the wire.

CONCLUSION

So far we have proposed a floating vessel which can extract the energy from wind or water current through resonant pitching motion. The main results of the investigation are as follows:

The formulation for the time series of the work and torque needed to rotate the flat plates in order to make a pitching motion of the vessel has been given.

The expressions for work and torque contain terms which are proportional to the second, third, and fourth powers of the width of the plates. Therefore it is more economical to use many plates with smaller widths.

The numerical simulation of the pitching motion showed that the motion depends on whether the half period of rotation of the plate is greater or less than the free mode of pitching motion of the vessel.

Since the free mode of the pitching motion is independent of the flow velocity, tuning the frequency to the flow velocity is not required.

The flow force which affects the vessel and the effect of the energy conversion process on the pitching motion of the vessel, have not been considered in this paper. These effects will be taken into account in future modification of the present dynamics model. We intend to focus future study on this and to evaluate energy gain for a particular energy conversion system.

REFERENCES

- Hadano, K, Taneura, K, Nakano, K, and Saito, T (2004). "Evaluation of Energy Obtained by Float Type Wave Energy Generation System," *Fourteenth Int Offshore and Polar Eng Conference*, ISOPE, pp 246-252.